

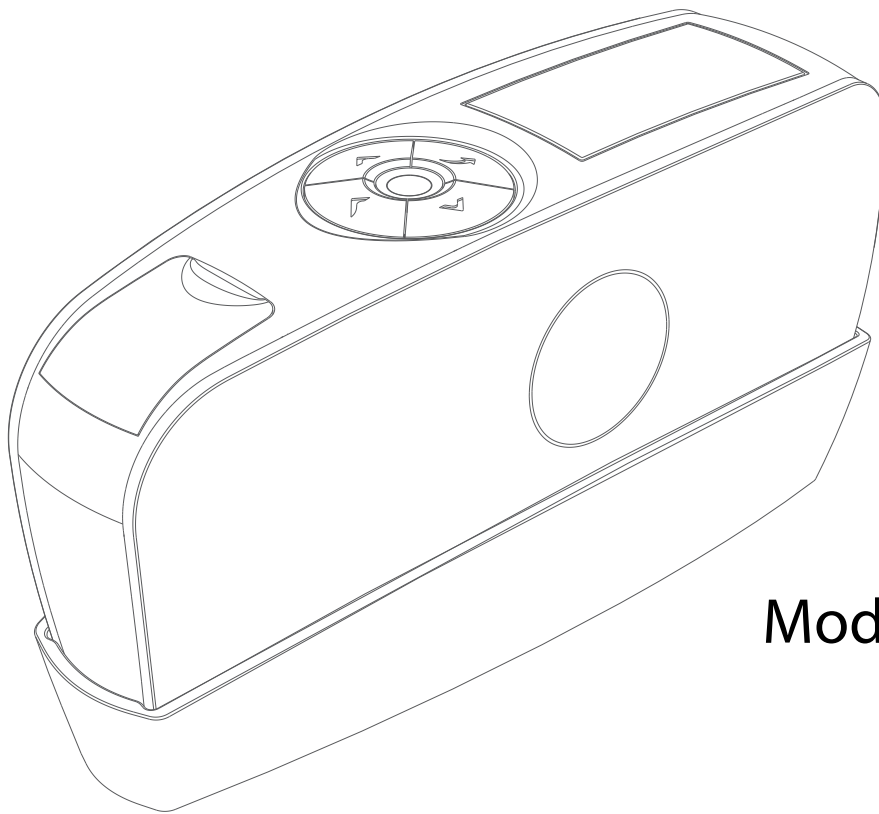

# HIGH ACCURACY GLOSS METER

OPERATION MANUAL



Model Numbers:

MRM-YG60  
MRM-YG60S  
MRM-YG268

V1.0

# Content

|   |    |
|---|----|
| Introduction .....                              | 1  |
| Cautions .....                                  | 1  |
| 1. External structure description.....          | 2  |
| 2. Switch on/off.....                           | 3  |
| 2.1 Startup.....                                | 3  |
| 2.2 Shutdown .....                              | 4  |
| 3. Basic operation.....                         | 4  |
| 3.1 Menu Operation.....                         | 4  |
| 3.2 Enter the main menu .....                   | 5  |
| 3.3 Confirm prompt interface .....              | 5  |
| 3.4 Input prompt interface.....                 | 6  |
| 3.5 Editing operation.....                      | 6  |
| 3.6 Display Item.....                           | 7  |
| <br>  |    |
| 5. Measurement Modes.....                       | 9  |
| 5.1 Switching Measurement Modes .....           | 9  |
| 5.2 Basic Mode.....                             | 10 |
| 5.2.1 Measurement.....                          | 10 |
| 5.2.2 Basic mode menu.....                      | 11 |
| 5.3 Quality Control Mode.....                   | 11 |
| 5.3.1 Interface Introduction .....              | 11 |
| 5.3.2 Measurement.....                          | 12 |
| 5.3.3 Measurement Standard .....                | 12 |
| 5.4 Statistical Mode.....                       | 13 |
| 5.4.1 Interface introduction .....              | 13 |
| 5.4.2 Measurement.....                          | 13 |
| 5.4.3 Measurement Standard .....                | 13 |
| 5.4.4 Set the number of measurements .....      | 14 |
| 5.4.5 Setting Display Options .....             | 14 |
| 5.5 Continuous mode.....                        | 15 |
| 5.5.1 Measurement.....                          | 15 |
| 5.5.2 Specified number of measurements .....    | 16 |
| 5.5.3 Specified measurement time interval ..... | 16 |
| 6. Data management.....                         | 17 |
| 6.1 Turn on/off the storage .....               | 17 |
| 6.2 View Records.....                           | 17 |
| 6.3 Delete records .....                        | 17 |
| 7. Standard management.....                     | 18 |
| 7.1 Turn on difference display .....            | 18 |

|   |    |
|---|----|
| 7.2 Browse/Edit/Delete Standards.....   | 18 |
| 7.3 Measurement Standards.....          | 19 |
| 7.4 Create Standards.....               | 19 |
| 7.5 Clear Standards.....                | 19 |
| 8. Switching angle.....                 | 20 |
| 9. System settings.....                 | 20 |
| 9.1 Language Settings.....              | 20 |
| 9.2 Bluetooth(Only partial models)..... | 20 |
| 9.3 Beep.....                           | 20 |
| 9.4 Auto Shutdown Options.....          | 20 |
| 9.5 Reset the Instrument.....           | 21 |
| 9.6 View Device Information.....        | 21 |
| 10. Technical Specifications.....       | 22 |
| 11. Simple troubleshooting.....         | 23 |

## Introduction

The high accuracy single angle and multi-angles gloss meters are independently developed by our company and have completely independent intellectual property rights. They conform to the international standard ISO 2813 and the Chinese national standard GB/T9754 and meet the requirements of the JJG696 first-class work gloss meter. It features with auto-calibration and basic mode, quality control mode, statistical mode and continuous mode to satisfy different measurement requirements, and it has standard accessory high-end quality management software.

This manual is only suitable for our single angle and multi-angles gloss meters.

All the operations are described for multi-angles, but almost all operations except angles switching are suitable for single-angle instrument.

## Cautions

1. The gloss meter is a precise measuring instrument. Please avoid dramatic change of external environment when measuring. Those changes including the flicker of surrounding light, the rapid change of temperature and humidity will affect the measuring accuracy.
2. Keep the instrument balanceable. Make sure the measuring aperture cling to the test sample, and no shaking or shifting when measuring. Please prevent the gloss meter from fierce collision or crash. This device is not water-proof. Do not use it in the environment of high humidity or in the mist.
3. Keep the device clean. Avoid dust, powder or solid particles entering the measuring aperture and the devices.
4. After using, please turn it off. Keep the instrument and calibration board in the instrument case.

5. Keep the instrument in a cool, dry environment.
6. Users can not do any changes on the device without permission. Since it may
7. affect measuring accuracy or even damage the device.

## 1. External structure description

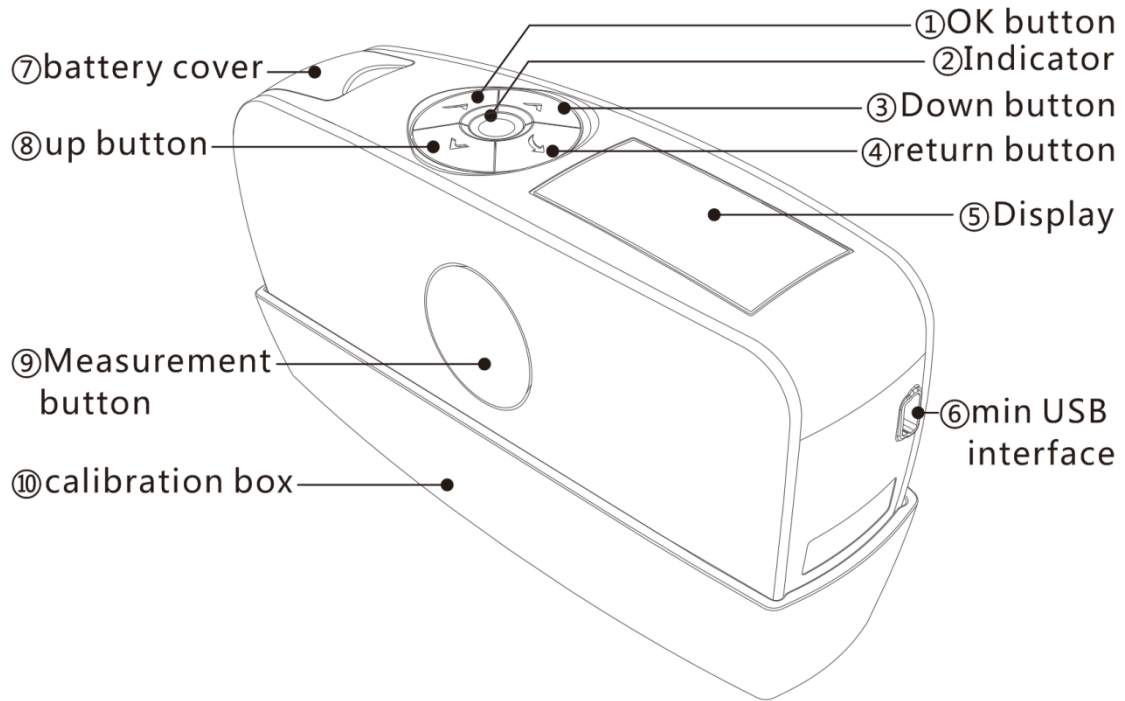







Figure 1 External structure of the instrument

| Button name         | Icon  | Function  |
|---------------------|---|---|
| ⑨Measurement button |  | Switch ON/OFF, measurement, quick return to measurement interface, operation confirmation |
| ①OK button          |  | Display menu, prompt or operation confirmation  |
| ④Return button      |  | Return to previous menu or cancel operation   |
| ⑧Up button          |  | Move up menu items  |
| ③Down button        |  | Move down menu items  |

Remark: Use the above icons to represent the corresponding buttons in the instrument operation prompt

## 2. Switch on/off

### 2.1 Startup

The instrument can use battery and USB power supply. When using the battery, press the measurement button to turn on the power; if using USB power, the instrument will automatically turn on when USB and the power is connected.

If the calibration box is detected during startup, the instrument will be calibrated automatically.

If the calibration is passed as shown in Figure 2, it will enter to the measurement interface saved at the last normal shutdown.

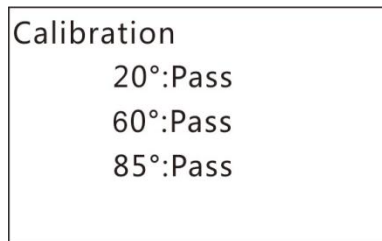

Figure 2 calibration pass

If the calibration is failure, it is as shown in Figure 3.

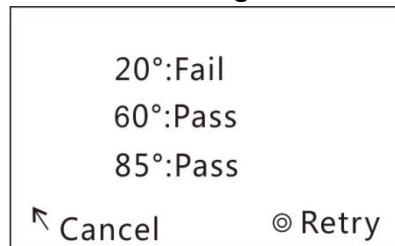

Figure 3 calibration fail

After the calibration is failure, please choose to press the measurement button to retry or press the return button to directly enter the measurement interface. If you try again, please check these first:

1. Whether the calibration box is in good connection or not;
2. Is the calibration tile clean?
3. Calibration tile protection paper is removed.

## 2.2 Shutdown

When using battery power, the instrument will automatically shut down within a certain period of time (30 seconds by default, which can be changed in the settings). It can also be turned off by pressing and holding the measurement button for more than 3 seconds.

It is not able to turn off when using USB power.

## 3. Basic operation

### 3.1 Menu Operation

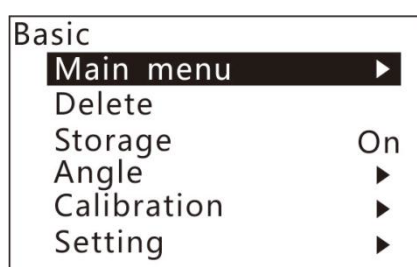

Figure 4 menu introduction

The "basic " in the figure is the menu title;

" Main menu " is the currently selected menu item;

" ► " means it has sub-menu items;

" ↓ " continues to page up and other menu items;

Click the OK button on the measurement interface to enter the menu interface.

Press up and down button to change the current selected item.

If there is a " ↓ " in the lower right corner, it means more menu items to view by paging down; if there is a " ↑ " in the upper right corner, it means more menu items to view by paging up.

If there is a " ► " on the right side of the menu item, click the OK button to enter the sub-menu item.

Tip 1: Normally press the measurement button on the menu interface to return to the measurement interface.

## 3.2 Enter the main menu

Press the OK button in the measurement interface to enter the menu of the corresponding mode, and select "Main Menu", then press the OK button to enter the main menu.

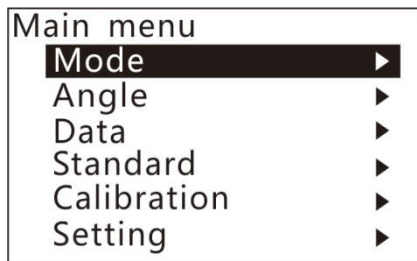

Figure 5 Main menu

The main menu contains the following items:

- 1.Mode: select the measurement mode;
- 2.Angle: select the measurement angle (only for multi-angles gloss meter);
- 3.Data: Turn on/off storage function; check and delete records;
- 4.Standard management: Turn on/off the difference value; check, modify, add and delete the standard;
- 5.Calibration: calibrate the instrument and modify the calibration parameters;
6. Setting: system setting.

## 3.3 Confirm prompt interface

The prompt interface is used to prompt to confirm an operation or not like deleting the record as shown in Figure 6.

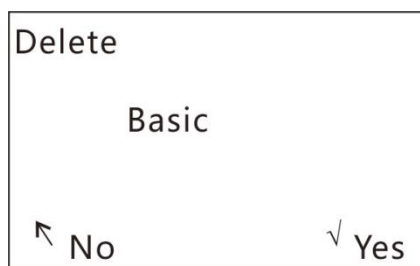

Figure 6 delete the record

Please press the OK button or the measurement button to confirm the corresponding operation or press the return button to cancel.

Tip 2: If confirming “No” in the prompt interface means pressing the return button to perform a “No” operation, and “Yes” means pressing the OK button to perform a “Yes” operation.

### 3.4 Input prompt interface

The input interface is mainly used for prompting input the sample name or number as shown in Figure 7.



Figure 7 input prompt interface

As shown in Figure 7, between the square brackets (between "[" and "]") is the input area, and the character on "^" is the current input focus.

Press the up or down button to switch the character at the focus position.

Press the OK button to move the input focus to the next position.

Press the measurement button to confirm the entry.

Press the return button to cancel the input operation.

### 3.5 Editing operation

The number or character displayed on the right side of some menu items is editable. For example, in the item of the average number of statistical modes, when press the OK button, it will display as shown in Figure 9, which is an edit area enclosed by square brackets. When display the editing area as shown in Figure 7, press the up and down buttons to switch the character at the focus, and press the OK button to move the edit focus to the next character, or press the return button to cancel the changes and press the measurement button to save the changes.

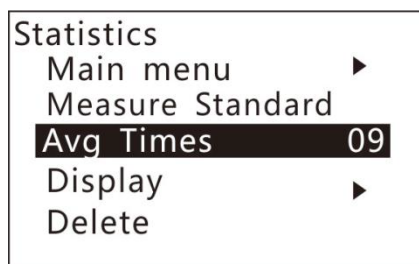

Figure 8 The number of average measurement is editable

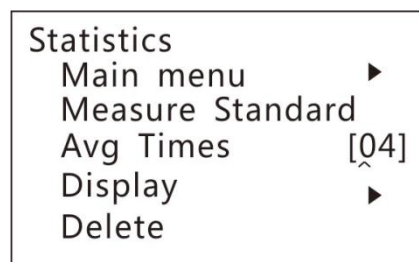

Figure 9 Press OK button to edit the number of average times

### 3.6 Display Item

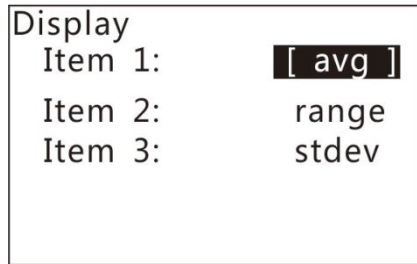

Figure 10 Editing display items

Some setting values can only be one of several options. For example, in the display item of the statistics mode, press the OK button to select other options.

When you edit an item, it is anti-color display and the current item are enclosed in square brackets.

Press the up or down button to switch the current option.  
Press the OK or measurement button to save the changes.  
Press the return button to restore the original value.

## 5. Measurement Modes

The instrument has four measurement modes. They are basic mode, quality control mode, statistical mode and continuous mode.

Please do the simple measurement in the basic mode; the quality control mode can compare the measurement result with the standard; the statistical mode can do many average measurements, and perform basic statistics on multiple measured data, also be compared with the standard; in the continuous mode, press the measurement button to automatically measure continuously for the times you set.

### 5.1 Switching Measurement Modes

The instrument is in the basic mode when it is turned on for the first time. Please enter the “main menu” and select the “measurement mode” menu item, then press the OK button to the “Mode” interface to change the measurement mode as shown in Figure 16. Select the appropriate measurement mode and press the OK button.

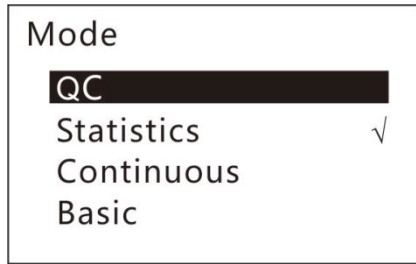

Figure 16 Measurement Mode Menu

## 5.2 Basic Mode

### 5.2.1 Measurement

Press the measurement button under the basic mode interface to measure.

During the measurement, the green indicator lights up, while the green indicator goes out after the measurement is completed and display the measurement results as shown in Figure 17.

|     |      |
|-----|------|
| 20° | 2.7  |
| 60° | 16.3 |
| 85° | 19.2 |

Figure 17 Basic Mode Measurement Results

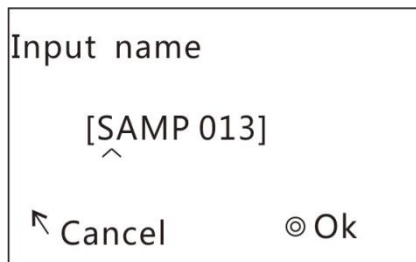

Figure 18 Enter the sample name

If the storage function is turned on, it prompts to enter the sample name after each measurement is completed as shown in Figure 18. The system will provide a default name and press the measurement button to confirm the name and save it or press the return button to cancel it.

Press the return button to delete the measurement result as shown in Figure 19.

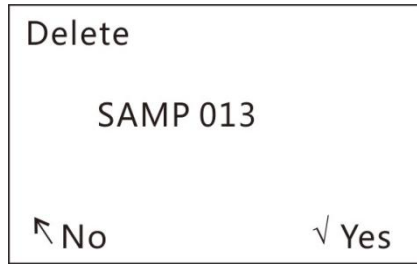

Figure 19 Press the return button to delete the measurement result

## 5.2.2 Basic mode menu

Press the OK button at the measurement interface to enter the basic mode menu.

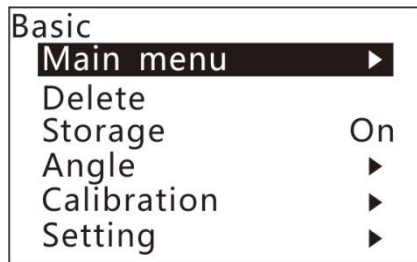

Figure 20 Basic Mode Menu

The basic mode menu contains the following menu items:

1. The main menu: enter the main menu;
2. Delete: Delete the current measurement result;
3. Storage: Enable or disable the storage function. If the storage function is turned on, "ON" will be displayed on the right, otherwise "OFF" will be displayed.
4. Angle: switch the instrument measurement angle (only for multi-angles instrument);
5. Calibration: instrument calibration related functions;
6. Setting: system settings menu.

## 5.3 Quality Control Mode

### 5.3.1 Interface Introduction

| TMP STD  | SAMP 001 |      |  |
|----------|----------|------|--|
| value    | diff     | pass |  |
| 20° 2.9  | 0.2      | OK   |  |
| 60° 16.7 | 0.3      | OK   |  |
| 85° 19.2 | 0.0      | OK   |  |

Figure 21 Quality Control Mode Measurement Interface

As shown in Figure 21, the "value" column shows the measured value; the "diff" column shows the difference between the sample value and the standard value; the "pass" column shows judgement results, and "OK" means within the tolerance of the standard, " NG" indicates out of tolerance.

If the difference display is not turned on, the measurement interface of the quality control mode is the same as the basic mode.

### 5.3.2 Measurement

Press the measurement button in the measurement interface to measure. The green light will light up during measurement, and will go out after the measurement is completed and the measurement result will be displayed.

### 5.3.3 Measurement Standard

Press the OK button to enter the quality control mode menu, then select the measurement standard. After the measurement is ready, press the OK button to measure. After the measurement is completed, the measurement result is displayed and prompted for confirmation as shown in Figure 22.

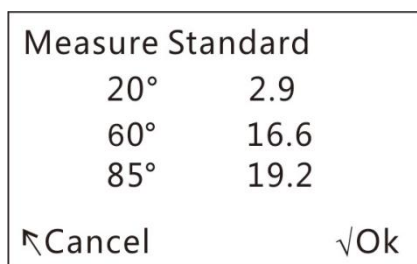

Figure 22 Confirm the measurement result of standard

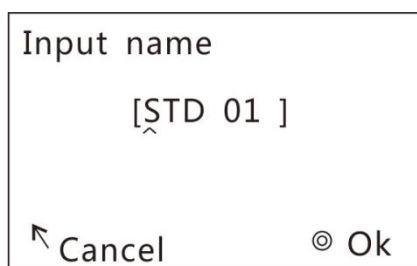

Figure 23 Enter the sample name

Press the OK button to confirm or press the return button to discard the result.

If the storage function is turned on, it prompts to enter the standard name after the confirmation is finished as shown in Figure 23.

After confirming the name of the standard, press the measurement button to save the standard or press the return button to cancel the storage. At this time the standard will be save as a temporary standard.

After the standard is measured, it is automatically set as the current standard; if the differential display is not turned on, it will be automatically turned on.

## 5.4 Statistical Mode

### 5.4.1 Interface introduction

As shown in Figure 24, in the top left corner of the statistics mode, it displays the current standard name. The first row in the upper right corner shows the current sample name, and the second row shows the number of measurements, which is displayed in the form of "m/n". "m" indicates the number of measured times and "n" indicates the total numbers of requirement measurement.

In the figure 24, "avg", "range", "stdev" each shows the average value, the variation range of m measurements, and the standard deviation. They can be changed in the Display Options in the Statistics Mode menu.

|       |          |       |       |
|-------|----------|-------|-------|
| STD02 | SAMP 001 |       |       |
|       |          |       | 4/4   |
|       | avg      | range | stdev |
| 20°   | 2.7      | 0.2   | 0.0   |
| 60°   | 15.6     | 1.0   | 0.0   |
| 85°   | 21.9     | 4.5   | 1.0   |

Figure 24 Statistics Mode Measurement Interface

### 5.4.2 Measurement

After entering the statistical mode measurement interface, press the measurement button to measure. The measurement result will be updated at each measurement, and measurement will be automatically performed after the specified number of measurements. If the storage is turned on, it will prompt to enter the sample name when measurement is finished.

Please press the down button to finish the current measurement if the setting numbers of measurements are not enough.

Please press the up button (this operation can only be performed when the measurement is not completed) to delete the previous measurement data.

Please press the return button to delete the measurement result.

### 5.4.3 Measurement Standard

Press the OK button to enter the statistical mode menu, then select the "Measure Standard" menu item, and press the OK button to enter the standard measurement interface.

The "m/n" in the top left corner of the measurement interface shows the current number of measurements and the total number of required measurements.

The "avg" column in the measurement interface shows the average of m measurements; the "min" column shows the minimum value in m measurements, and "max" shows the maximum value in m measurements.

| Measure Standard |      |      |      |
|------------------|------|------|------|
|                  |      |      | 3/4  |
|                  | avg  | min  | max  |
| 20°              | 2.9  | 2.8  | 3.0  |
| 60°              | 17.2 | 16.7 | 17.8 |
| 85°              | 20.1 | 18.8 | 21.1 |

Figure 25 Statistics mode measurement standard interface

After entering the standard measurement interface, press the measurement button to measure. After measuring for a specified number of times, if the storage is turned on, it will be prompt to input the standard name, otherwise it is set as a temporary standard.

During the measurement, press the return button to cancel the measurement or press the OK button to complete the measurement.

#### 5.4.4 Set the number of measurements

Enter the statistics mode menu and select the "Average" menu item, then press the OK button to modify the number of measurements.

The number of measurements in the statistical mode can be set from 2 to 99 .

#### 5.4.5 Setting Display Options

After entering the statistics mode menu, select the "Display Options" menu item, and then press the OK button to enter the display options setting page.

The statistical mode measurement interface can display up to three columns, corresponding to the first, second and third items respectively.

The available display items are:

1. "avg": average;
2. "min" : the minimum value of the measured value;
3. "max" : the maximum value of the measured value;
4. "range" : the value that the maximum value minus the minimum value;
5. "stdev" : standard deviation;

- 6. "diff" : difference that minus the standard deviation;
- 7. "pass": the result of comparison with the standard sample, "OK" or "NG";
- 8. Blank: Do not display.

The standard deviation calculation formula is:

$$\text{stdev} = \sqrt{\frac{\sum_1^n (x_i - \bar{x})^2}{n - 1}}$$

## 5.5 Continuous mode

### 5.5.1 Measurement

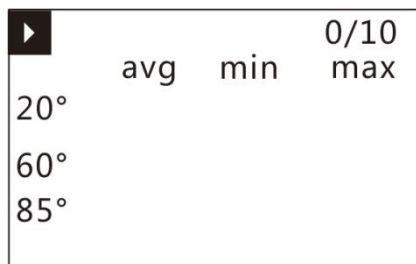

Figure 26 Continuous Measurement Interface (Ready)

Press the measurement button in the continuous measurement interface to start measurement.

If the storage is enabled, it will prompt to enter a name before the measurement. This name will be used as the first measurement name as shown in Figure 27, and subsequent measurements will be automatically incremented based on the name.

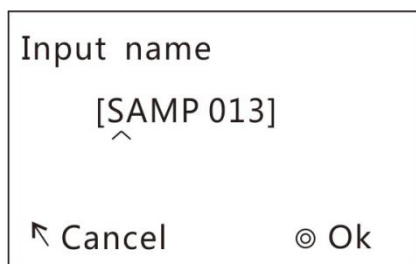

Figure 27 Enter the name of the first measurement

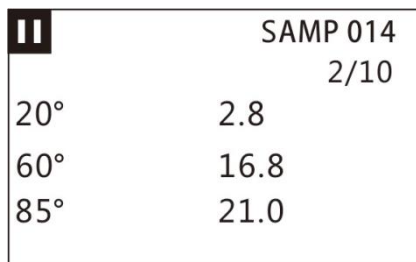

Figure 28 Continuous Measurement Interface (measured)

As shown in Figure 28, it will display each measurement result and the times that are measuring.

Press the measurement button or the return button during measurement to pause the measurement. When the measurement is paused, the average value ("avg" column), minimum value ("min" column), and maximum value ("max" column) of all measured samples are displayed as shown in Figure 29. Press the measurement button again to continue measurement.

|     |      |      |      |  |
|-----|------|------|------|--|
| ▶   | □    | 3/4  |      |  |
|     | avg  | min  | max  |  |
| 20° | 2.8  | 2.8  | 2.8  |  |
| 60° | 16.8 | 16.7 | 16.8 |  |
| 85° | 21.0 | 20.9 | 21.0 |  |

Figure 29 Continuous Measurement Interface (Pause)

Press the OK button while paused to abort the measurement and press the OK button again to display the continuous mode menu.

When the measurement is performed a specified number of times, the measurement is stopped and the average, minimum, and maximum values of all measured samples are displayed.

|     |       |      |      |  |
|-----|-------|------|------|--|
| ▶   | 10/10 |      |      |  |
|     | avg   | min  | max  |  |
| 20° | 2.8   | 2.8  | 2.9  |  |
| 60° | 16.8  | 16.7 | 16.8 |  |
| 85° | 21.0  | 20.9 | 21.0 |  |

Figure 30 Continuous Measurement Interface (Complete)

### 5.5.2 Specified number of measurements

In the measurement interface, press the OK button to enter the continuous mode menu (If measurement is in progress, it needs to stop the measurement first), and select the "measurement times" menu item then press the OK button to modify. The number of measurements can be specified from 1 to 999 .

### 5.5.3 Specified measurement time interval

In the measurement interface, press the OK button to enter the continuous mode menu (If measurement is in progress, it needs to stop the measurement first), and select the "Measurement interval" menu item then press the OK button to modify.

The measurement time interval can be specified from 2 to 120 seconds.

The measurement time interval refers to the interval of two measurements.

## 6. Data management

Enter the main menu to select the "Storage" menu item and press the OK button to enter the data management interface.

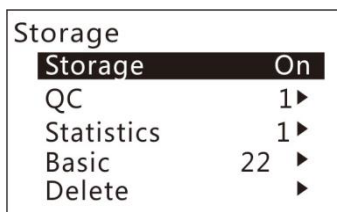

Figure 31 Storage Menu

### 6.1 Turn on/off the storage

Select the "Storage" menu item and press the OK button. After modifying the switch options, press the measurement button to save the changes.

### 6.2 View Records

Record types are divided into quality control records, statistical records, and basic records. The quality control records store the quality control measurement results; the statistical records store the statistical measurement results; the basic records store the basic model and continuous model measurement results.

To view the corresponding record, select the appropriate record and press the OK button to start browsing.

Press the up or down button during browsing to switch the records.

Press the return button to return to the storage menu.

Press the measurement button to return to the measurement interface.

### 6.3 Delete records

Select the "Delete" item of the storage and press the OK button to enter the "Delete" menu. Then select the record type to delete, press the OK button after selecting, and it will prompt to confirm the operation by pressing the OK button or the measurement button or cancel it by pressing the return button.

Note: The delete operation will empty all corresponding records at once, so please operate with caution.

## 7. Standard management

In the main menu, select "Standard Management" and press the OK button to enter the standard management menu.

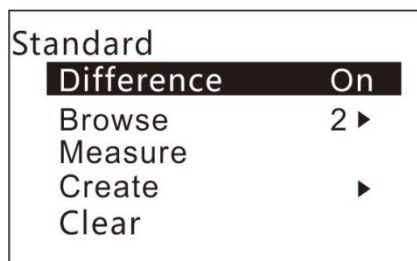

Figure 32 Standard Management Menu

### 7.1 Turn on difference display

In the standard management menu, select "Difference Display" and press the OK button to modify the difference display switch. After the modification, press the measurement button or OK button to save the changes.

### 7.2 Browse/Edit/Delete Standards

In the standard management menu, select "Browse Standards" and press the OK button to enter the browse standards interface as shown in Figure 33.

| Standard |       | STD 01 |       |
|----------|-------|--------|-------|
|          | value | lower  | upper |
| 20°      | 2.9   | 0.0    | 2000  |
| 60°      | 16.6  | 0.0    | 2000  |
| 85°      | 19.2  | 0.0    | 2000  |

Figure 33 View standards interface

In the figure 33, the upper right corner shows the standard name. If it is the current standard, "\*" will be displayed in front of the name.

"value" is the target value of the standard, "lower" is the lower limit of the qualified sample, and "upper" is the upper limit. In the quality control or statistical mode, within the range of upper and lower limits are "OK", exceeding it is "NG".

Press the up or down button while browsing the standard to switch the standard.

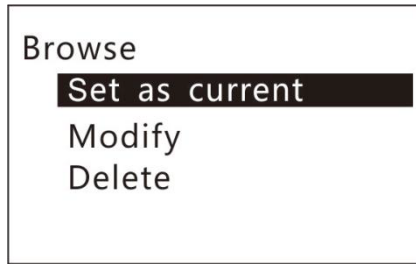

Figure 34 View standards Menu

Press the OK button to open the browse standards menu, as shown in Figure 34. The View standards menu includes:

1. Set as the current standard: set the browse standard as the current standard;
2. Modify the standard: modify the name and value of the viewing standard;
3. Delete: delete the viewing standard.

### 7.3 Measurement Standards

In the standard management menu, select "Measure" and press the OK button to perform the measurement.

Use average measurements in statistical mode, otherwise use basic measurements.

The average measurements procedure is similar to the standard measurement under the statistical mode standard menu. The basic measurement is similar to the standard measurement in the quality control mode.

### 7.4 Create Standards

Select "Create" in the standard management menu and press the OK button to create a new standard, as shown in Figure 35. Then, in the "Create Standards" interface, modify the name of the Standard and set the target value and upper and lower limits for each angle.

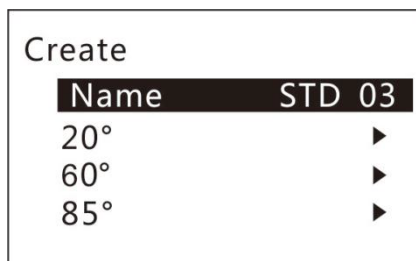

Figure 35 Create Standards Interface

### 7.5 Clear Standards

Clear Standards will delete all stored standards.

In the standard management menu, select "Clear" and then press the OK button. The system will prompt to confirm. Press the measurement button or OK button to execute the emptying operation or cancel it by pressing the return button.

## 8. Switching angle

For multi-angles instruments, it is able to modify the measurement angle.

In the main menu, select "Geometry" and press the OK button. Then select the angle to use when measuring and press the OK button.

## 9. System settings

In the main menu, select the "Setting" menu item and press the OK button to enter the System Settings menu.

### 9.1 Language Settings

After selecting "Language Settings" in the system settings menu, press the OK button to enter the language menu. Select the required language and press the OK button to set it as the system language.

### 9.2 Bluetooth(Only partial models)

For models supporting Bluetooth, there is "Bluetooth" item in the system menu. Choose "Bluetooth" item and press confirm button, select "on", then press confirm button or test button to save and open the function of Bluetooth. If close it, select "off" and press confirm button or test button.

About Bluetooth connect to PC software please refer to the related software.

Note: When Bluetooth function is turned on, even if not in use, it also consumes electricity. So turn off Bluetooth if do not use it.

### 9.3 Beep

In the system settings menu, select the "Beep" menu item and press the OK button, then modify the switch options. After the modification is completed, press the OK button or the measurement button to save the changes.

### 9.4 Auto Shutdown Options

In the Setup menu, select the "Auto Shutdown" menu item and press the OK button, then modify the idle waiting time for automatic shutdown.

The automatic shutdown time can be set to 30 seconds, 60 seconds, 90 seconds, 2 minutes, or never shut down.

Automatic shutdown is only valid when using battery power, and it can not be turned off when using USB power.

## **9.5 Reset the Instrument**

Reset the instrument when the system is abnormal.

Resetting the instrument will erase all user data and settings except calibration tile parameters, so please use it with caution.

Press the OK button after selecting "Reset Instrument" in the system menu. At this time, the system will prompt to execute the operation or not. If confirm to execute the operation, please press the OK button or measurement button, or cancel the operation by pressing the return button.

## **9.6 View Device Information**

In the system menu, select "Device Information" and press the OK button to view the device information.

The device information includes the instrument model ("Model"), serial number ("SN"), software version number ("S.V."), and hardware version number ("H.V.").

## 10. Technical Specifications

|                       |   |
|-----------------------|---|
| Measurement Angle     | 20°/60°/85°/20°60°85°   |
| Standard              | ISO 2813、GB/T 9754、ASTM D 523、ASTM D 2457   |
| Measuring Area(mm)    | 20°: 9X10 60°: 9X15 85°: 5X38   |
| Measuring Range       | 20°: 0 ~ 2000GU 60°: 0 ~ 1000GU 85°: 0 ~ 160GU  |
| Division Value        | 0.1 GU  |
| Accuracy              | Conform with JJG696 first class gloss meter working requirements  |
| Repeat ability        | 0~100GU: ±0.2GU ; 100~2000GU: ±0.2%GU   |
| Automatic switch time | 30 seconds, 60 seconds, 90 seconds, two minutes or never shut down  |
| Calibration           | Automatically Calibration when startup/manual calibration   |
| Measuring Time        | 0.5 seconds per angle   |
| Dimension             | 160X52X84mm   |
| Weight                | About 300g (including calibration box and battery)  |
| Measurement mode      | Basic mode, Statistical mode, Continuous mode, Quality control mode                                       |
| Display               | 2.3 inch black and white display  |
| Language              | Simplified Chinese, English, Traditional Chinese  |
| Storage               | 35,000(Basic mode/Continuous mode:15,000 Quality control mode: 10,000 Statistical mode:10,000)            |
| Power supply          | 1 pcs AA battery (Alkaline or NiMH rechargeable battery) for 1000 times measurement; or use USB port      |
| Interface             | USB   |
| PC Software           | GQC6 Quality Control Software with QC report printing function and more extended functions                |
| Operation Temperature | 0~40°C (32~104°F)   |
| Storage Temperature   | -20~50°C (-4~122°F)   |
| Humidity              | <85% relative humidity, no condensation   |
| Standard Accessories  | USB cable, User Manual, GQC6 software (Official website download or after sales offer), Calibration board |

\*Note: The specifications are subject to change without notice.

## 11. Simple troubleshooting

| Problem Description                   | Treatment method  |
|---------------------------------------|---|
| Instrument can not start-up           | Please check whether the battery is inside or the battery has power or not;<br>Using USB Power to check if it is connected or the USB cable is damaged.   |
| Automatically shutdown after start-up | Replace new battery   |
| Large deviation in measurement data   | Confirm that the measured object is aligned with the measuring port during measurement and close to the instrument.<br>Please re-calibrate the instrument;<br>Check that the battery is fully charged.                  |
| Calibration failed                    | Check whether the calibration box is in good connection; the calibration board is clean; calibration board protection paper is removed.   |
| Abnormal sampling                     | Replace the new battery;<br>Check if there is a lot of radiation in the work environment.   |
| USB cannot connect to PC              | Re-plug USB;<br>Check if the USB cable has problems;<br>Check if the USB driver is installed;<br>Check if the operating system is activated;<br>Try to start the PC software with administrator privileges.             |
| Unable to install USB driver          | Check if the PC has sufficient rights;<br>Check if the CPU is too new and not compatible with the operating system (Intel's Newer CPU Installs Windows 10 Operating System Below Will Cause USB Drive to Fail to Work). |



MRM Metrology Inc.  
905 595 1000  
sales@MRMmetrology.com  
www.MRMmetrology.com