

Digital Indicator Applications

Thickness Gages SERIES 547

Standard Type (Resolution: 0.0005 in)

- Thickness gages can quickly measure the thickness of thin products such as paper and felt.
- Using a ceramic contact and anvil, there is no need to worry about rust. (except for **547-400A**)



547-301A



547-321A

SPECIFICATIONS

Inch / Metric

Order No.	Resolution	Range (in)	Measuring depth	Contact point, Anvil	Parallelism of Contact point, Anvil
547-526S*	0.0001 in/0.001 mm	0 - 0.47*	1.18 in (30 mm)	ø0.39 in (ø10 mm) Flat	0.0002 in/0.005 mm
547-300A	0.0005 in/0.01 mm	0 - 0.4	1.18 in (30 mm)	ø0.39 in (ø10 mm) Flat	0.005 in/0.01 mm
547-500S*	0.0005 in/0.01 mm	0 - 0.47*	1.18 in (30 mm)	ø0.39 in (ø10 mm) Flat	0.005 in/0.01 mm
547-320A	0.0005 in/0.01 mm	0 - 0.4	4.72 in (120 mm)	ø0.39 in (ø10 mm) Flat	0.005 in/0.01 mm
547-520S*	0.0005 in/0.01 mm	0 - 0.47*	4.72 in (120 mm)	ø0.39 in (ø10 mm) Flat	0.005 in/0.01 mm

Order No.	Accuracy	Measuring force (N)	Mass (g)	Remarks
547-526S*	±0.0002 in/±5 μm	1.5 or less	225	Standard, ceramic point/anvil
547-300A	±0.001 in/±20 μm	1.5 or less	245	Standard, ceramic point/anvil
547-500S*	±0.001 in/±20 μm	1.5 or less	225	Standard, ceramic point/anvil
547-320A	±0.001 in/±20 μm	1.5 or less	385	Deep throat, ceramic point/anvil
547-520S*	±0.001 in/±20 μm	1.5 or less	380	Deep throat, ceramic point/anvil

* Using ID-SX Digimatic indicator.

Metric

Order No.	Resolution (mm)	Range (mm)	Measuring depth (mm)	Contact point, Anvil (mm)	Parallelism of Contact point, Anvil (μm)
547-301A	0.01	0 - 10	30	ø10 Flat	10
547-321A	0.01	0 - 10	120	ø10 Flat	10

Order No.	Accuracy (μm)	Measuring force (N)	Mass (g)	Remarks
547-301A	±20	1.5 or less	245	Standard, ceramic point/anvil
547-321A	±20	1.5 or less	385	Deep throat, ceramic point/anvil

DIMENSIONS

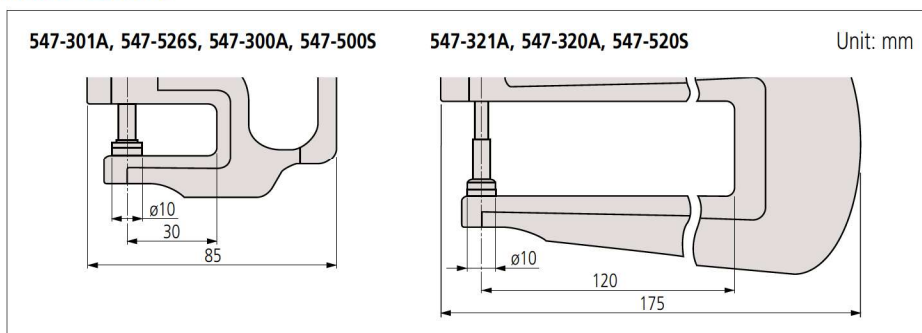

- Display: 6-digit display, sign (7-digit for models with 0.0005 mm resolution)
- Power source: CR2032 battery (1 pc.), included as standard (for operational checks)
- Zero-setting (INC system)
- Presetting (ABS system)
- Measuring direction switching
- Tolerance judgment
- Function Lock
- Calibration schedule warning function
- Data output
- Display value holding (when no external device is connected)
- 330° rotary display
- Low battery voltage alarm display
- Error alarm display

Optional Accessories

Refer to page F-90.

- Measurement Data Management **USB-ITPAK V3.0: 06AGR543**

Digital Indicator Applications

Optional Accessories

Order No.	Type	Description
264-020	—	USB Input Tool Series USB Keyboard Signal Conversion Type IT-020U
06AGL011	SF	Connection cable (1 m)
06AGL021	SF	Connection cable (2 m)
06AGQ001F	SF	USB Input Tool Direct (2 m)
264-622	IP67	U-WAVE-TM
264-623	Buzzer	U-WAVE-TM
02AZD810D	—	U-WAVE-R
264-626	IP67	U-WAVE-TMB
264-627	Buzzer	U-WAVE-TMB
02AZF700	—	Connecting unit for U-WAVE-TM/TMB (for ID-C/ID-F Series 12.7 mm/0.5 inch type only)
02AZF670	—	U-WAVE-TM/TMB mounting bracket: for Digimatic Indicators

High Accuracy Type (Resolution: 0.00002 in)



547-401A

SPECIFICATIONS

Inch / Metric

Order No.	Resolution	Range (in)	Measuring depth	Contact point, Anvil	Parallelism of Contact point, Anvil
547-400A	0.00002/0.00005 / 0.0001/0.0005 in 0.0005/0.001 / 0.01 mm (selectable)	0 - 0.47	0.83 in (21 mm)	ø0.25 in (ø6.3 mm) Flat	0.0001 in/0.003 mm

Order No.	Accuracy	Measuring force (N)	Mass (g)	Remarks
547-400A	±0.00012 in/±3 μm	3.5 or less	275	High accuracy, carbide point anvil

Metric

Order No.	Resolution (mm)	Range (mm)	Measuring depth (mm)	Contact point, Anvil (mm)	Parallelism of Contact point, Anvil (μm)
547-401A	0.0005 (0.001/0.01 selectable)	0 - 12	21	ø6.3 Flat (Carbide)	3

Order No.	Accuracy (μm)	Measuring force (N)	Mass (g)	Remarks
547-401A	±3	3.5 or less	275	High accuracy, carbide point anvil

DIMENSIONS

547-401A, 547-400A

Unit: mm

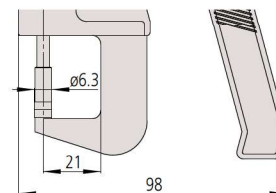

Dial Indicator Applications

Thickness Gages SERIES 7

Standard Type (Graduation: 0.0005 in)

- Integrated moulding of the bezel and crystal ensures protection against water and oil penetration via the front face.



7301A



7321A

SPECIFICATIONS

Inch					
Order No.	Graduation (in)	Range (in)	Measuring depth (in)	Contact point, Anvil (in)	Parallelism of Contact point, Anvil (in)
7326A	0.0001	0 - 0.05	1.18	ø0.39 Flat	0.0002
7300A	0.001	0 - 0.5	1.18	ø0.39 Flat	0.0005
7304A	0.001	0 - 1	1.18	ø0.39 Flat	0.0005
7322A	0.001	0 - 1	4.72	ø0.39 Flat	0.0005

Order No.	Accuracy (in)	Measuring force (N)	Mass (g)	Remarks
7326A	±0.0002	2.0 or less	205	Fine dial reading, ceramic point/anvil
7300A	±0.001	1.8 or less	205	Standard, ceramic point/anvil
7304A	±0.002	1.8 or less	220	Standard, ceramic point/anvil
7322A	±0.002	1.8 or less	370	Deep throat, ceramic point/anvil

Metric					
Order No.	Graduation (mm)	Range (mm)	Measuring depth (mm)	Contact point, Anvil (mm)	Parallelism of Contact point, Anvil (µm)
7327A	0.001	0 - 1	30	ø10 Flat	5
7301A	0.01	0 - 10	30	ø10 Flat	5
7305A	0.01	0 - 20	30	ø10 Flat	5
7321A	0.01	0 - 10	120	ø10 Flat	5
7323A	0.01	0 - 20	120	ø10 Flat	5

Order No.	Accuracy (µm)	Measuring force (N)	Mass (g)	Remarks
7327A	±5	1.5 or less	225	Fine dial reading, ceramic point/anvil
7301A	±15	1.4 or less	205	Standard, ceramic point/anvil
7305A	±20	2.0 or less	220	Standard, ceramic point/anvil
7321A	±15	1.4 or less	370	Deep throat, ceramic point/anvil
7323A	±22	2.0 or less	370	Deep throat, ceramic point/anvil

Note: The dial indicator needs to be reset when a contact point is replaced.

DIMENSIONS

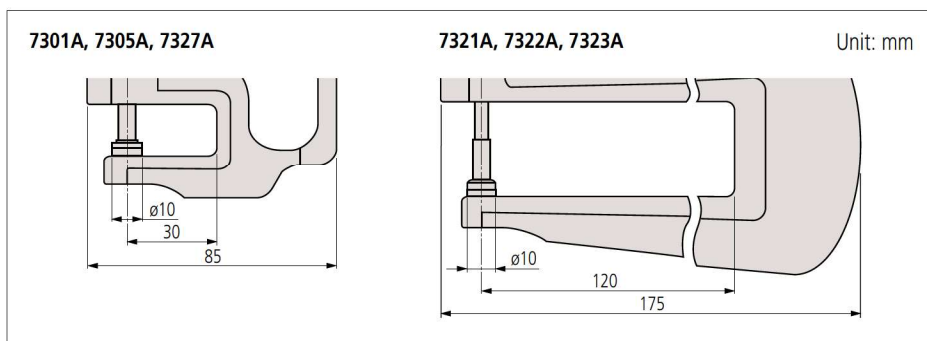

Dial/Digital Indicator Applications

Typical applications

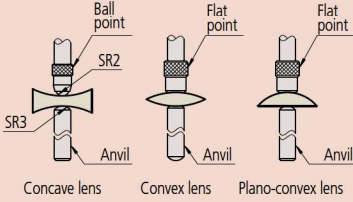

- Display: 6-digit display, sign
- Power source: CR2032 battery (1 pc.), included as standard (for operational checks)
- Zero-setting (INC system)
- Presetting (ABS system)
- Measuring direction switching
- Tolerance judgment
- Function Lock
- Calibration schedule warning function
- Data output
- Display value holding (when no external device is connected)
- 330° rotary display
- Low battery voltage alarm display
- Error alarm display

Optional Accessories

Refer to page F-90.

- Measurement Data Management **USB-ITPAK V3.0: 06AGR543**

Lens thickness measurement

- Thickness of concave-convex lenses and surfaces can be measured. (Contact point, Anvil: hardened steel)
- Anvils and contact points are interchangeable to enable concave surfaces to be measured.
- Provided with a ball point as standard.



SPECIFICATIONS

Inch / Metric

Order No.	Resolution	Range (in)	Measuring depth	Contact point, Anvil	Parallelism of Contact point, Anvil
547-312A	0.0005 in/0.01 mm	0 - 0.4	1.18 in (30 mm)	ø6 mm (ø0.24 in) Flat (Contact point) ø4.8 mm (ø0.19 in) Flat (Anvil)	0.005 in/0.01 mm
547-512A*	0.0005 in/0.01 mm	0 - 0.47*	1.18 in (30 mm)	ø6 mm (ø0.24 in) Flat (Contact point) ø4.8 mm (ø0.19 in) Flat (Anvil)	0.005 in/0.01 mm

Order No.	Accuracy	Measuring force (N)	Mass (g)	Remarks
547-312A	±0.001 in/±20 µm	1.5 or less	265	Lens thickness
547-512A*	±0.001 in/±20 µm	1.5 or less	240	Lens thickness

* Using ID-SX Digimatic indicator.

Metric

Order No.	Resolution (mm)	Range (mm)	Measuring depth (mm)	Contact point, Anvil (mm)	Parallelism of Contact point, Anvil (µm)
547-313A	0.01	0 - 10	30	ø6 Flat (Contact point) ø4.8 Flat (Anvil)	12

Order No.	Accuracy (µm)	Measuring force (N)	Mass (g)	Remarks
547-313A	±20	1.5 or less	265	Lens thickness

Inch

Order No.	Graduation (in)	Range (in)	Measuring depth (in)	Contact point, Anvil (in)	Parallelism of Contact point, Anvil (in)
7312A	0.001	0 - 0.5	1.18	ø0.24 Flat (Contact point) ø0.19 Flat (Anvil)	0.0005

Order No.	Accuracy (in)	Measuring force (N)	Mass (g)	Remarks
7312A	±0.001	1.8 or less	215	Lens thickness

Metric

Order No.	Graduation (mm)	Range (mm)	Measuring depth (mm)	Contact point, Anvil (mm)	Parallelism of Contact point, Anvil (µm)
7313A	0.01	0 - 10	30	ø6 Flat (Contact point) ø4.8 Flat (Anvil)	5

Order No.	Accuracy (µm)	Measuring force (N)	Mass (g)	Remarks
7313A	±15	1.4 or less	215	Lens thickness

Note: The dial indicator needs to be reset when a contact point is replaced.

DIMENSIONS

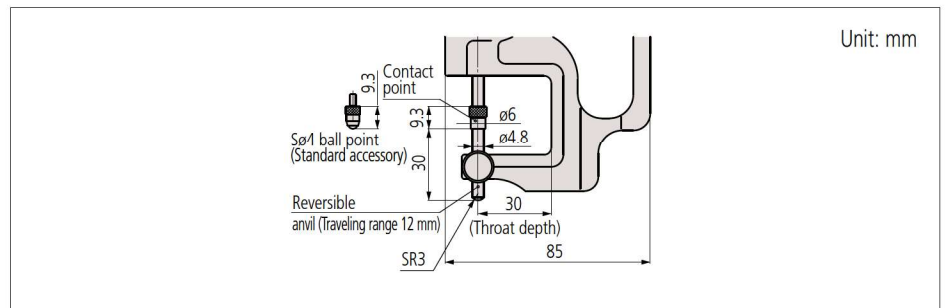

Unit: mm

Dial/Digital Indicator Applications

MeasurLink ENABLED
Data Management Software by Mitutoyo

Thickness Gages SERIES 547, 7

Pipe gage measurement

- Pipe wall thickness, thickness of curved boards can be measured. (Contact point, Anvil: hardened steel)



547-360A

7360A

SPECIFICATIONS

Inch / Metric				
Order No.	Resolution	Range (in)	Measuring depth	Contact point, Anvil
547-361A	0.0005 in/0.01 mm	0 - 0.4	0.79 in (20 mm)	ø3 mm (ø0.12 in) Flat (Contact point) ø3.5 mm (ø0.14 in) Ball (Anvil)
547-561S	0.0005 in/0.01 mm	0 - 0.47*	0.79 in (20 mm)	ø3 mm (ø0.12 in) Flat (Contact point) ø3.5 mm (ø0.14 in) Ball (Anvil)
Order No.	Accuracy	Measuring force (N)	Mass (g)	Remarks
547-361A	±0.001 in/±20 µm	1.5 or less	230	Pipe gage
547-561S	±0.001 in/±20 µm	1.5 or less	215	Pipe gage

* Using ID-SX Digimatic indicator.

Metric				
Order No.	Resolution (mm)	Range (mm)	Measuring depth (mm)	Contact point, Anvil (mm)
547-360A	0.01	0 - 10	20	ø3 Flat (Contact point) ø3.5 Ball (Anvil)
Order No.	Accuracy (µm)	Measuring force (N)	Mass (g)	Remarks
547-360A	±20	1.5 or less	230	Pipe gage

Inch				
Order No.	Graduation (in)	Range (in)	Measuring depth (in)	Contact point, Anvil (in)
7361A	0.001	0 - 0.5	0.8	ø0.12 Flat (Contact point) ø0.14 Ball (Anvil)
Order No.	Accuracy (in)	Measuring force (N)	Mass (g)	Remarks
7361A	±0.001	1.8 or less	200	Pipe gage

Metric				
Order No.	Graduation (mm)	Range (mm)	Measuring depth (mm)	Contact point, Anvil (mm)
7360A	0.01	0 - 10	20	ø3 Flat (Contact point) ø3.5 Ball (Anvil)
Order No.	Accuracy (µm)	Measuring force (N)	Mass (g)	Remarks
7360A	±15	1.4 or less	200	Pipe gage

Note: The dial indicator needs to be reset when a contact point is replaced.

DIMENSIONS

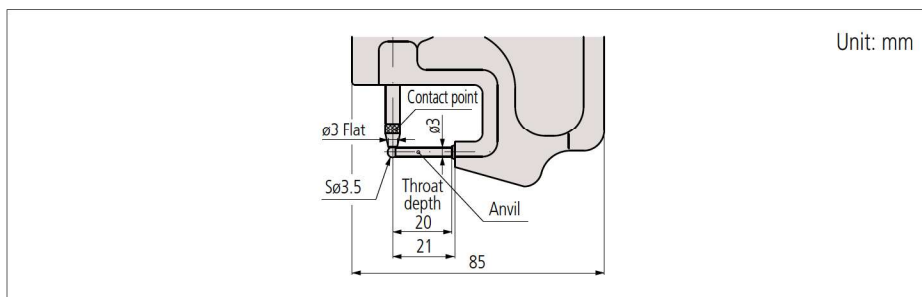

- Display: 6-digit display, sign
- Power source: CR2032 battery (1 pc.), included as standard (for operational checks)
- Zero-setting (INC system)
- Presetting (ABS system)
- Measuring direction switching
- Tolerance judgment
- Function Lock
- Calibration schedule warning function
- Data output
- Display value holding (when no external device is connected)
- 330° rotary display
- Low battery voltage alarm display
- Error alarm display

Optional Accessories

Refer to page F-90.

- Measurement Data Management **USB-ITPAK V3.0: 06AGR543**

Dial/Digital Indicator Applications

- Display: 6-digit display, sign
- Power source: CR2032 battery (1 pc.), included as standard (for operational checks)
- Zero-setting (INC system)
- Presetting (ABS system)
- Measuring direction switching
- Tolerance judgment
- Function Lock
- Calibration schedule warning function
- Data output
- Display value holding (when no external device is connected)
- 330° rotary display
- Low battery voltage alarm display
- Error alarm display

Optional Accessories

Refer to page F-90.

- Measurement Data Management **USB-ITPAK V3.0: 06AGR543**

Blade thickness measurement

- Measuring faces of the contact point and anvil are blade-shaped (thickness: 1 mm). Suitable for measuring narrow grooves.



547-315A

7315A

SPECIFICATIONS

Inch / Metric

Order No.	Resolution	Range (in)	Measuring depth	Contact point, Anvil	Parallelism of Contact point, Anvil
547-316A	0.0005 in/0.01 mm	0 - 0.4	1.18 in (30 mm)	t=1 mm (0.04 in) Blade	0.005 in/0.01 mm
547-516A*	0.0005 in/0.01 mm	0 - 0.47*	1.18 in (30 mm)	t=1 mm (0.04 in) Blade	0.005 in/0.01 mm

Order No.	Accuracy	Measuring force (N)	Mass (g)	Remarks
547-316A	±0.001 in/±20 μm	1.5 or less	260	Blade thickness
547-516A*	±0.001 in/±20 μm	1.5 or less	240	Blade thickness

* Using **ID-SX** Digimatic indicator.

Metric

Order No.	Resolution (mm)	Range (mm)	Measuring depth (mm)	Contact point, Anvil (mm)	Parallelism of Contact point, Anvil (μm)
547-315A	0.01	0 - 10	30	t=1 Blade	10

Order No.	Accuracy (μm)	Measuring force (N)	Mass (g)	Remarks
547-315A	±20	1.5 or less	260	Blade thickness

Inch

Order No.	Graduation (in)	Range (in)	Measuring depth (in)	Contact point, Anvil (in)	Parallelism of Contact point, Anvil (in)
7316A	0.001	0 - 0.5	1.18	t=0.04 Blade	0.0005

Order No.	Accuracy (in)	Measuring force (N)	Mass (g)	Remarks
7316A	±0.001	1.8 or less	220	Blade thickness

Metric

Order No.	Graduation (mm)	Range (mm)	Measuring depth (mm)	Contact point, Anvil (mm)	Parallelism of Contact point, Anvil (μm)
7315A	0.01	0 - 10	30	t=1 Blade	5

Order No.	Accuracy (μm)	Measuring force (N)	Mass (g)	Remarks
7315A	±15	1.4 or less	220	Blade thickness

Note: The dial indicator needs to be reset when a contact point is replaced.

DIMENSIONS

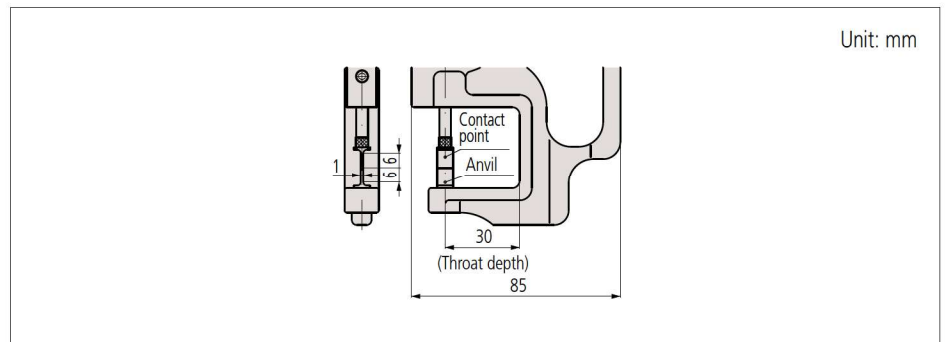

MRM Metrology Inc.
905 595 1000
sales@MRMmetrology.com
www.MRMmetrology.com