





















AS 3100.X2 PLUS Analytical Balance



The drawings, photos and graphics used are for illustrative purposes only.

Functions

-  Autotest
-  Dosing
-  Percent Weighing
-  Parts counting
-  Peak hold
-  Formulation
-  Newton unit measurement
-  Statistics
-  Checkweighing
-  IR sensors
-  Under-pan weighing
-  GLP Procedures
-  Animal weighing
-  Density determination
-  Ambient conditions monitoring
-  Replaceable unit
-  Statistical Quality Control
-  ALIBI Memory
-  Mass for titrator
-  Wi-Fi

Datasheet

Metrological parameters	
Maximum capacity [Max]	3100 g
Minimum load	-
Readability [d]	1 mg
Verification unit [e]	-

Metrological parameters	
Tare range	-3.1 kg
Standard repeatability [5% Max]	0.5 mg
Standard repeatability [Max]	0.6 mg
Standard minimum weight (USP)	1 g
Standard minimum weight (U=1%, k=2)	100 mg
Permissible repeatability [5% Max]	0.8 mg
Permissible repeatability [Max]	1 mg
Linearity	±4 mg
Stabilization time	2 s
Adjustment	internal (automatic)
OIML Class	-

Physical parameters	
Leveling system	semi-automatic - LevelSENSING
Display	5" graphic color touchscreen
Weighing chamber doors	manual
Delivery components	Balance, weighing pan, weighing pan shield, centring ring, bottom cover, power supply.
Weighing chamber dimensions	190×190×222 mm
Weighing pan dimensions	ø90 mm (open-work pan)
Packaging dimensions	545×455×575 mm
Net weight	7.3 kg
Gross weight	9.3 kg

Construction	
Protection class	IP 43

Components and software	
Database capacity	7

Features of use	
Touch-free operation	2 IR Sensors

Communication interface	
Communication interface	RS232 ¹ , 2×USB-A (interchangeable), USB-B, Wi-Fi, Ethernet

Electrical parameters	
Power supply	Adapter: 100 – 240V AC 50/60Hz 0.6A; 12V DC 1.2A Balance: 12 – 15V DC 0.8A max
Power consumption max.	4 W

Environmental conditions	
Operating temperature	+10 ÷ +40 °C
Ambient conditions monitoring (option)	THBR 2.0 System, THBR BOX, THB P, THB W, THB S
Relative humidity	40% ÷ 80%

Repeatability is expressed as a standard deviation from 10 weighing cycles.

Stabilization time depends on the ambient conditions and the dynamics of weighing pan loading; specified for FAST profile.

¹ Barcode scanners, available as weighing instrument accessory, communicate with the instrument via RS232 interface exclusively.



Accessories

Antivibration Tables
Holders for laboratory flasks
Cigarette lighter receptacle power supply cables
Density determination KIT
USB cable (scale - printer)
Professional Weighing Tables
Barcode scanners
Holders for test tubes and filters
Workstation for Pipettes Calibration
RS 232, RS 485 cables
THBR 2.0 System - Ambient Conditions Monitoring

Displays
Protective cover for balances
Weighing dishes
Antistatic ionizer
Receipt Printer
RS 232, RS 485 cables
Additional modules
Under-pan weighing
RS 232 cables (scale - printer)
RS 232 – RS 485 Converter

Software

- RAD Key [WX-010-0005]
- R-Lab [WX-010-0080]
- RADWAG Development Studio [WX-010-0104]
- Alibi Reader [WX-010-0114]
- Scale Editor 2.1 [WX-010-0173]

Device dimensions

AS X2 PLUS, d = 0.01 mg

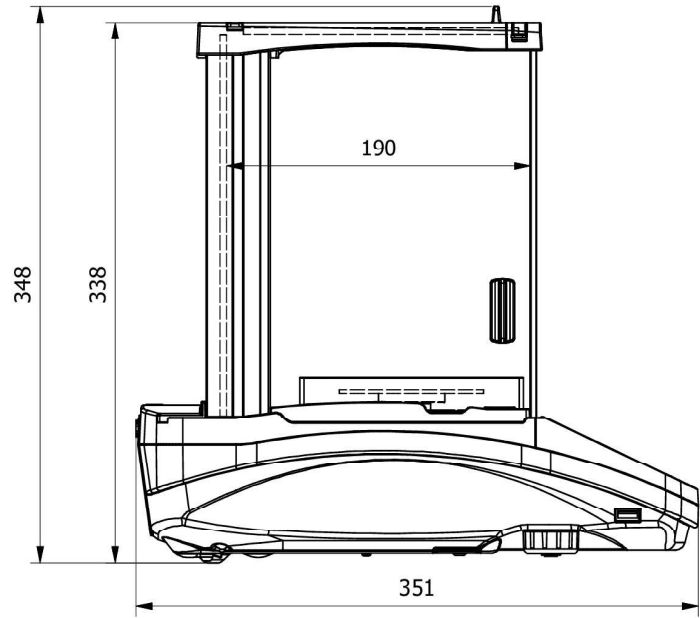
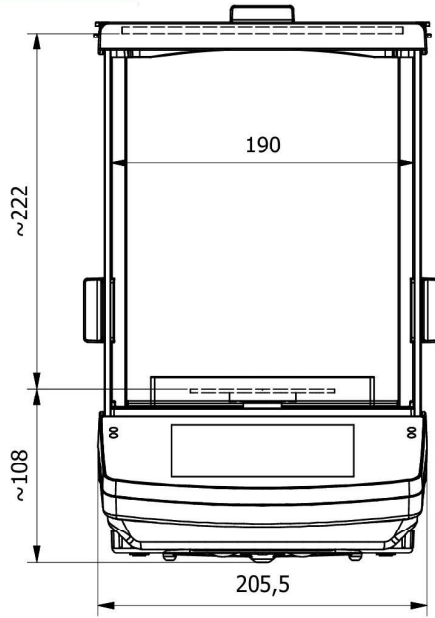

AS X2 PLUS, d = 0.1 mg

