

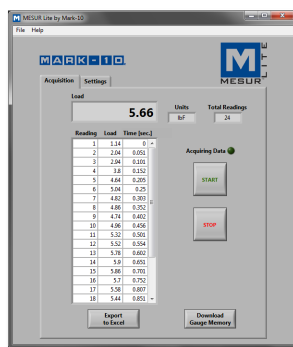

Series TT03 digital torque gauges are designed for clockwise and counter-clockwise torque testing applications in virtually every industry, with capacities from 10 ozFin to 100 lbFin (7 to 1,150 Ncm). A dedicated remote torque sensor with Jacobs chuck can be used to grip a sample, bit, or fixture. The gauges' rugged aluminum housing allows for hand-held use or test stand mounting for more sophisticated testing requirements.

Series TT03 features a sampling rate of 2,000 Hz, producing accurate results under a wide range of test conditions. A backlit graphic LCD displays large characters, and a menu is available to access the gauges' features and configurable parameters. USB output is provided for data collection purposes.

Set point indicators are provided for pass-fail testing. The gauges are overload protected to 150% of capacity, and an analog load bar is shown on the display for graphical representation of applied torque.



The gauges include MESUR® Lite data acquisition software, for tabulation of continuous or individual data points. One-click export to Excel button easily allows for further data manipulation.

< MESUR® Lite data acquisition software is included with Series TT03 gauges

Features

- Ergonomic torque sensor with Jacobs chuck
- Peak torque values saved and displayed
- High-speed 2,000 Hz sampling rate
- USB data output of continuous or individual data points
- Programmable set points with pass/fail indicators
- Live load bar graph with set point markers
- Peak CW and CCW readings always displayed
- Set points always displayed
- Configurable audio alarms and key tones
- MESUR® Lite data collection software included

Display Indicators



Optional Items



AC1008
Tabletop stand for indicator
 Conveniently positions the indicator for easy viewing. Includes thumb screws to for indicator installation and thru holes for bench mounting.



AC1007
Tabletop stand for sensor
 Secures the sensor in a horizontal orientation.

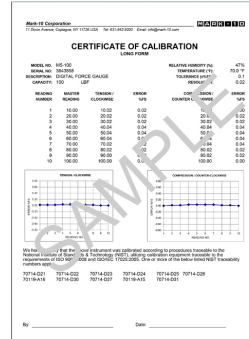

CERT
Calibration certificate with data
 Includes 10 data points in each measurement direction (short form certificate without data is included).

Specifications

Accuracy:	± 0.5% of full scale
Sampling Rate:	2,000 Hz
Power:	AC adapter: 100-240VAC, 50-60 Hz, 0.3 A Battery: Rechargeable 8.4V NiMH Low battery indicator appears when battery level is low, and gauge powers off automatically when power reaches critical stage.
Battery life:	Backlight on: up to 7 hours of continuous use Backlight off: up to 24 hours of continuous use
Measurement Units:	ozFin, lbFin, kgFmm, Ncm (depending on model)
USB Output:	Configurable up to 115,200 baud.
Safe overload:	150% of full scale (display shows "OVER" at 110% and above)
Weight:	1.8 [0.8 kg]
Environmental requirements:	40 - 100°F, max. 96% humidity, non-condensating
Warranty:	3 years (see individual statement for further details)

Dimensions in [mm]

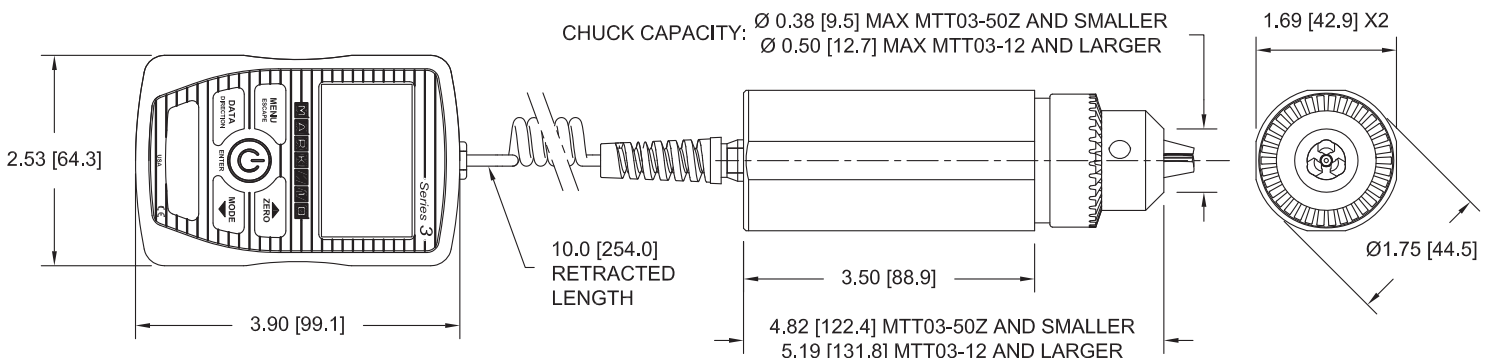

In The Box

Series TT03 torque gauges are shipped as shown at right, and include the following accessories:

- (1) Carrying case
- (1) Chuck key
- (1) USB cable
- (1) AC adapter
- (1) Battery
- (1) Certificate of calibration without data (data is optional)



Capacity & Resolution

Model No.	ozFin	lbFin	kgFmm	Ncm
MTT03-10Z	10 x 0.01	-	7 x 0.005	7 x 0.005
MTT03-20Z	20 x 0.02	-	14 x 0.01	14 x 0.01
MTT03-50Z	50 x 0.05	-	36 x 0.05	35 x 0.05
MTT03-12	192 x 0.2	12 x 0.01	-	135 x 0.1
MTT03-50	800 x 0.5	50 x 0.05	-	570 x 0.5
MTT03-100	1600 x 1	100 x 0.1	-	1150 x 1

All models include 110V AC adapters, unless ordered as below:

Add suffix 'E' for euro plug (220V), 'U' for UK plug (220V) or 'A' for Australian plug (220V).

Example: MTT03-50ZE, MTT03-50U, .A



1 Regan Road, Unit 1
 Brampton, Ontario, Canada
 L7A 1B8

Tel. 905 595 1000
 Sales@MRMmetrology.com
 Service@MRMmetrology.com
 www.MRMmetrology.com