

Bore Gages

SERIES 511 — for Small Holes

FEATURES

- Interchangeable anvils are made of alloy steel.
- The dial indicator is fully protected by a rugged cover.

SPECIFICATIONS

Metric Gage Stem \varnothing 8mm

Measuring Range	Order No. Without Dial Gage	Order No. With 2046SB Graduation 0.01mm	Order No. With 2109SB-10 Graduation 0.001mm	Number of Anvils	Number of Spacers
6 - 10mm	511-209*	511-211	511-210	9	1
10 - 18.5mm	511-201*	511-204	511-203	9	1

*Does not come with Dial Gage Protector Cover (21DZA000)

Inch Gage Stem Dia .375"

Measuring Range	Order No. Without Dial Gage	Order No. With 2922SB Graduation .0005"	Order No. With 2923SB-10 Graduation .0001"	Number of Anvils	Number of Spacers
.24 - .4"	511-214*	511-213	511-212	9	1
.4 - .74"	511-205*	511-207	511-206	9	1

*Does not come with Dial Gage Protector Cover (21DZA000)

DIMENSIONS

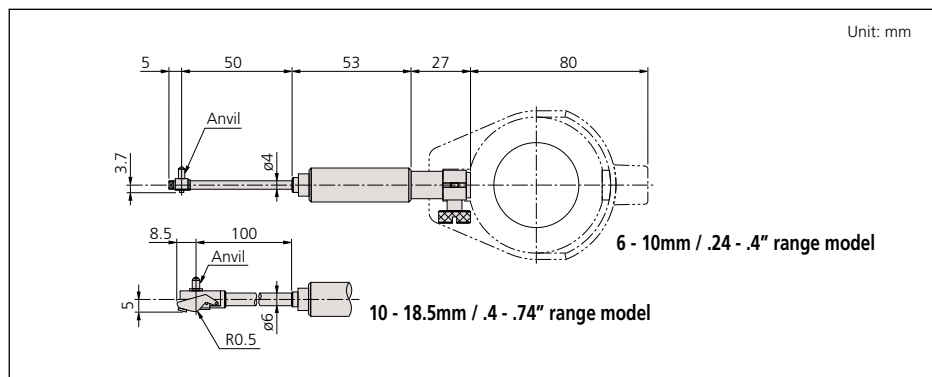

511-204

Technical Data

Accuracy: $5\mu\text{m} / .0002''$
 Indication stability: $2\mu\text{m} / .00008''$
 Graduation: 0.01mm, 0.001mm, .0005" or .0001"

Measuring Heads

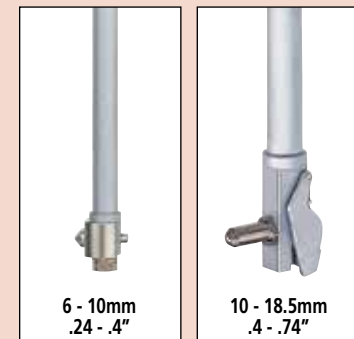

6 - 10mm
.24 - .4"

10 - 18.5mm
.4 - .74"

Optional Accessories

21DZA000: Dial Gage Protector Cover
 -----: Setting ring (See page C-29.)

Bore Gages

SERIES 511—Standard Type

Mitutoyo offers a complete selection of bore gages, all of them with interchangeable anvils and necessary accessories to perform close tolerance ID measurements.

FEATURES

- Carbide-tipped contact points for durability.
- The dial indicator is fully protected by a rugged cover.
- Optional extension rods can be attached for measuring deep holes.



511-743

SPECIFICATIONS

Inch		Gage Stem \varnothing 3/8"			
Measuring Range	Order No. Without Indicator	Order No. With 2922SB Graduation .0005"	Order No. With 2923SB-10 Graduation .0001"	Number of Anvils	Number of Spacers
.7 - 1.4"	511-731*	511-741	511-751	9	2
1.4 - 2.5"	511-732*	511-742	511-752	6	4
2.0 - 6.0"	511-733*	511-743	511-753	11 (2" sub anvil)	4
4.0 - 6.5"	511-734*	511-744	511-754	13	4
6.5 - 10"	511-735*	511-745	511-755	6	7
10 - 16"	511-736*	511-746	511-756	5 (3" sub anvil)	7
.7 - 6"	—	511-931	511-932	26 (2" sub anvil)	10

*Does not come with Dial Gage Protector Cover (21DZA000)

Metric		Gage Stem \varnothing 8mm			
Measuring Range	Order No. Without Indicator	Order No. With 2046SB Graduation 0.01mm	Order No. With 2109SB-10 Graduation 0.001mm	Number of Anvils	Number of Spacers
18 - 35mm	511-701*	511-711	511-721	9	2
35 - 60mm	511-702*	511-712	511-722	6	4
50 - 150mm	511-703*	511-713	511-723	11 (50mm Sub Anvil)	4
100 - 160mm	511-704*	511-714	511-724	13	4
160 - 250mm	511-705*	511-715	511-725	6	7
250 - 400mm	511-706*	511-716	511-726	5 (75mm Sub Anvil)	7
18 - 150mm	—	511-921 (3 pc set)	511-922 (3 pc set)	26 (50mm Sub Anvil)	10

*Does not come with Dial Gage Protector Cover (21DZA000)

Technical Data

Accuracy: $2\mu\text{m} / .00008"$

Indication stability: $1\mu\text{m} / .00004"$

Graduation: 0.01mm, 0.001mm, .0005" or .0001"



511-712

Contact Point

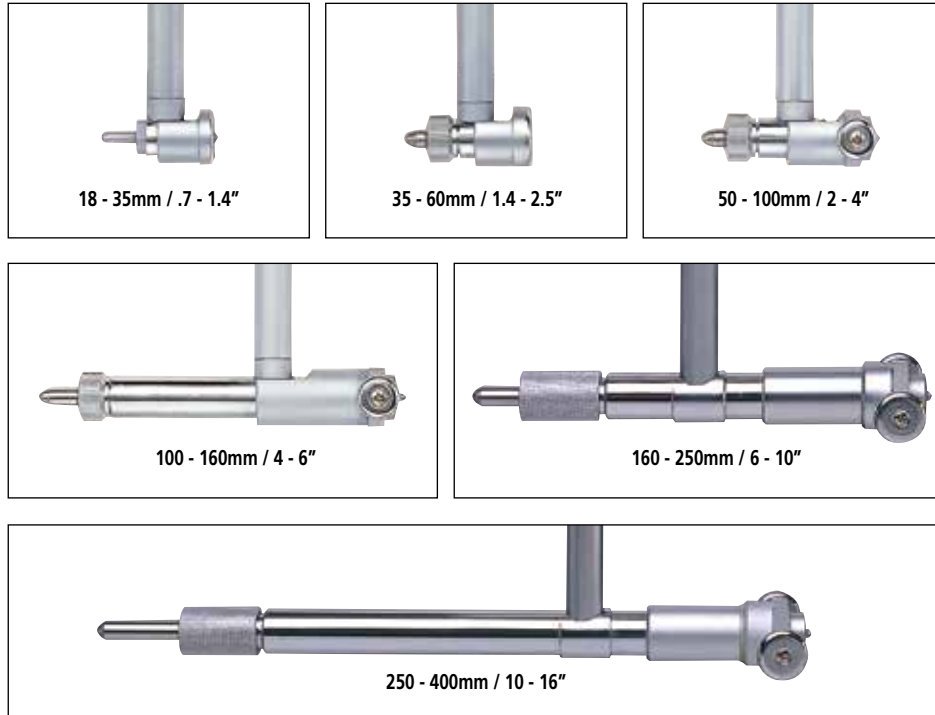

DIMENSIONS

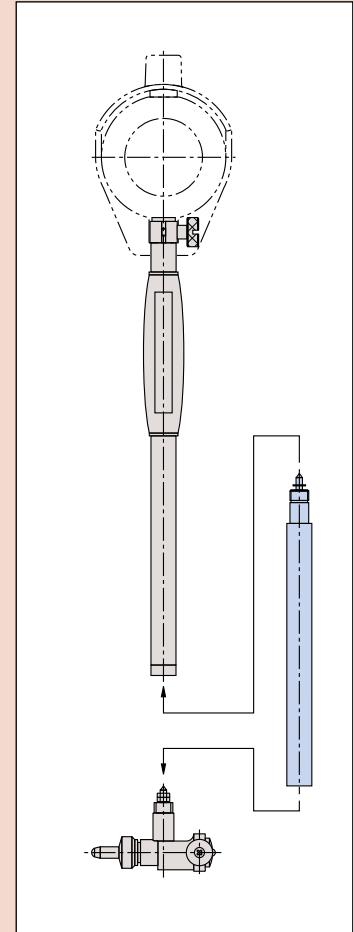
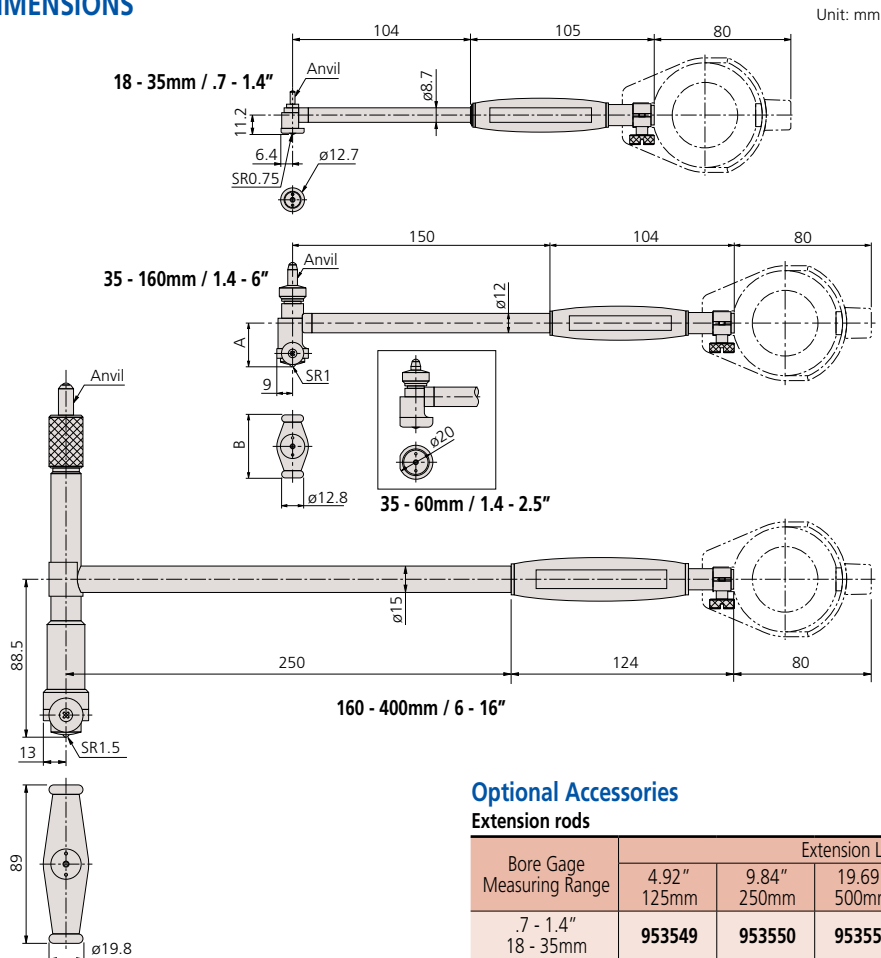

Setting ring (See page C-29.)

Optional Accessories

Extension rods

Bore Gage Measuring Range	Extension Length					Rod Diameter	Spanner
	4.92" 125mm	9.84" 250mm	19.69" 500mm	29.53" 750mm	39.37" 1000mm		
.7 - 1.4" 18 - 35mm	953549	953550	953551	-	-	.34" 8.7mm	102148
1.4 - 6.5" 35 - 160mm	953552	953553	953554	953555	953556	.47" 12mm	212556
6.5 - 16" 160 - 400mm	953557	952361	953558	953559	953560	.59" 15mm	212556

Note: Above list is used for 511-1XX series; not available for 511-2XX Series.



511-786

Technical Data

Accuracy: $2\mu\text{m} / .00008''$
 Indication stability: $1\mu\text{m} / .00004''$
 Graduation: 0.01mm, 0.001mm, .0005" or .0001"

Contact Point

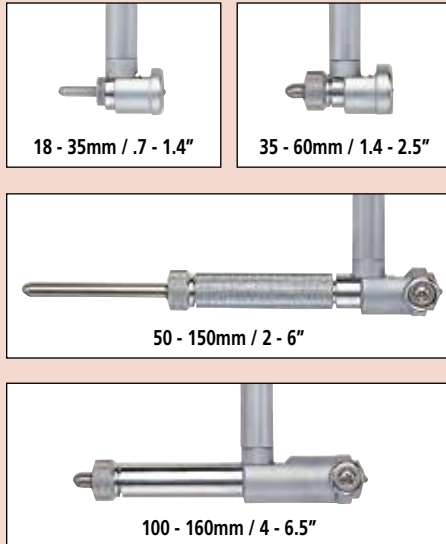

Bore Gages

SERIES 511 — Short-Leg Type

FEATURES

- Compact and lightweight because of the short length below the grip.
- Carbide-tipped contact point for durability.

SPECIFICATIONS

Inch		Gage Stem $\varnothing 3/8''$		
Measuring Range	Order No. With 2922SB Graduation .0005"	Order No. With 2923SB-10 Graduation .0001"	Number of Anvils	Number of Spacers
.7 - 1.4"	511-786	511-791	9	2
1.4 - 2.5"	511-787	511-792	6	4
2.0 - 6.0"	511-788	511-793	11 (2" sub anvil)	4
4.0 - 6.5"	511-789	511-794	13	4

Metric		Gage Stem $\varnothing 8\text{mm}$		
Measuring Range	Order No. With 2046SB Graduation 0.01mm	Order No. With 2109SB-10 Graduation 0.001mm	Number of Anvils	Number of Spacers
18 - 35mm	511-766	511-771	9	2
35 - 60mm	511-767	511-772	6	4
50 - 150mm	511-768	511-773	11 (50mm Sub Anvil)	4
100 - 160mm	511-769	511-774	13	4

DIMENSIONS

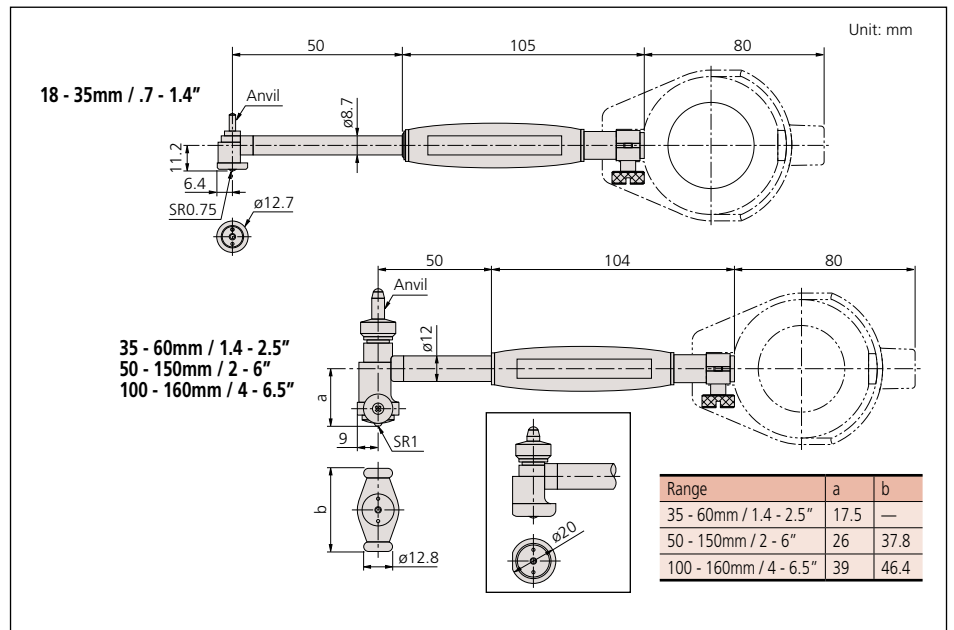

Optional Accessories

---- : Setting ring (See page C-29.)

Bore Gages

SERIES 511 — for Blind Holes

FEATURES

- Measure ID at position close to the bottom of blind holes.
- Carbide-contact point ensures high durability and wear resistance.
- Grip is large and hollow to reduce effect of body heat on high-accuracy measurements.



511-426

SPECIFICATIONS

Metric Gage Stem \varnothing 8mm

Measuring Range	Order No. Without Dial Gage	Order No. With 2046SB Graduation 0.01mm	Order No. With 2109SB-10 Graduation 0.001mm	Number of Anvils	Number of Spacers
15 - 35mm	511-415*	511-425	511-435	11 10mm Sub-Anvil	1
35 - 60mm	511-416*	511-426	511-436	6	4
50 - 150mm	511-417*	511-427	511-437	11 50mm Sub-Anvil	4

*Does not come with Dial Gage Protector Cover (21DZA000)

Inch Gage Stem Dia. .375"

Measuring Range	Order No. Without Dial Gage	Order No. With 2922SB Graduation .0005"	Order No. With 2923SB-10 Graduation .0001"	Number of Anvils	Number of Spacers
.6 - 1.4"	511-418*	511-428	511-438	11 .4" Sub-Anvil	1
1.4 - 2.4"	511-419*	511-429	511-439	6	4
2 - 6"	511-420*	511-430	511-440	11 2" Sub-Anvil	4

*Does not come with Dial Gage Protector Cover (21DZA000)

Contact Points

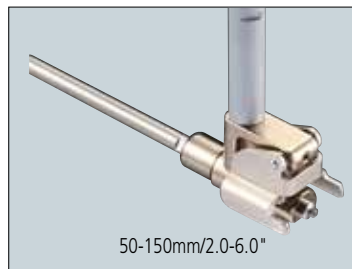
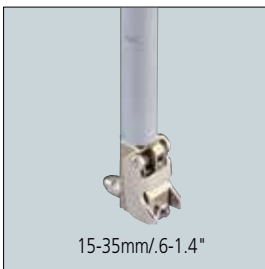

DIMENSIONS

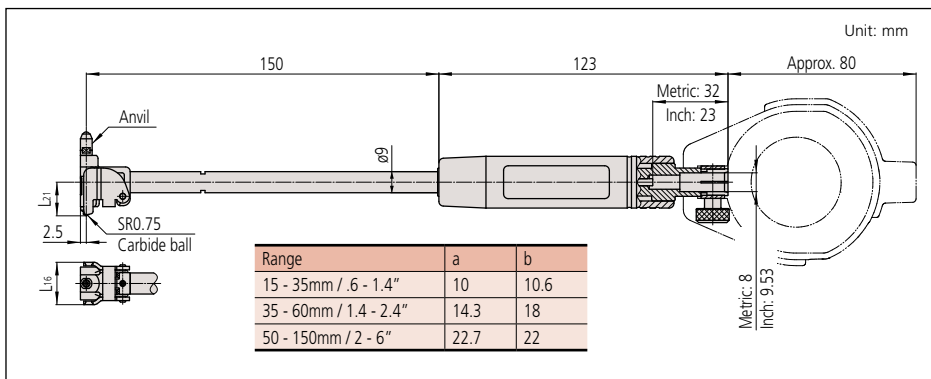

Technical Data

Accuracy: $4\mu\text{m}/.00016''$
 Indication stability: $1\mu\text{m}/.0004''$
 Graduation: 0.01mm, 0.001mm, .0005" or .0001"

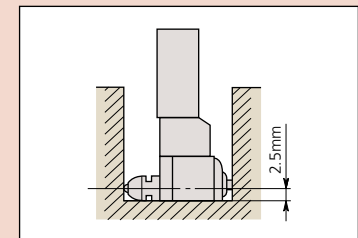

Optional Accessories

----- : Setting ring (See page C-29.)



511-843

Technical Data

Accuracy: $2\mu\text{m} / .00008''$
 Indication stability: $1\mu\text{m} / .00004''$
 Graduation: 0.01mm, 0.001mm, .0005" or .0001"

Bore Gages

SERIES 511 — with Micrometer Head

FEATURES

- Interchangeable anvil is attached to a micrometer head for accurate dimensional setting.
- Wide measuring range with sub-anvils.
- Carbide ball contact point for durability.
- Extension rods (optional) can be attached for measuring deep holes.
- Optional setting rings offer the best method of zero-setting bore gages.

SPECIFICATIONS

Inch		Gage Stem $\varnothing 3/8''$			
Measuring Range	Order No. Without Indicator	Order No. With 2922SB Graduation .0005"	Order No. With 2923SB-10 Graduation .0001"	Mic Head Travel	Sub Anvil
2.4 - 4.0"	511-833*	511-843	511-853	.4"	.4", .8"
4.0 - 6.4"	511-834*	511-844	511-854	.5"	.4", .8", .8"
6.0 - 10"	511-835*	511-845	511-855	.5"	.4", .8", .8", 2"
10 - 16"	511-836*	511-846	511-856	1"	1", 2", 2"
16 - 24"	511-837*	511-847	511-857	2"	2", 4"
24 - 32"	511-838*	511-848	511-858	2"	2", 4"

*Does not come with Dial Gage Protector Cover (21DZA000)

Metric		Gage Stem $\varnothing 8\text{mm}$			
Measuring Range	Order No. Without Indicator	Order No. With 2046SB Graduation 0.01mm	Order No. With 2109SB-10 Graduation 0.001mm	Mic Head Travel	Sub Anvil
60 - 100mm	511-803*	511-813	511-823	10mm	10mm, 20mm
100 - 160mm	511-804*	511-814	511-824	13mm	10mm, 20mm, 20mm
150 - 250mm	511-805*	511-815	511-825	13mm	10mm, 20mm, 20mm, 50mm
250 - 400mm	511-806*	511-816	511-826	25mm	25mm, 50mm, 50mm
400 - 600mm	511-807*	511-817	511-827	50mm	50mm, 100mm
600 - 800mm	511-808*	511-818	511-828	50mm	50mm, 100mm

*Does not come with Dial Gage Protector Cover (21DZA000)

Optional Accessories

Extension rods

Bore Gage Measuring Range	Extension Length					Rod Diameter	Spanner
	4.92" 125mm	9.84" 250mm	19.69" 500mm	29.53" 750mm	39.37" 1000mm		
2.4-6.4" 60 - 160mm	953552	953553	953554	953555	953556	.47" 12mm	212556
6.0 - 32.0" 150-800mm	953557	952361	953558	953559	953560	.59" 15mm	212556

Note: Not available for 511-2XX Series.

Contact Point



35 - 60mm / 1.4 - 2.5"



60 - 100mm / 2.4 - 4"

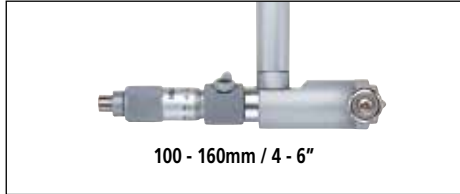

100 - 160mm / 4 - 6"

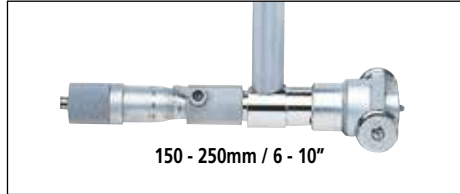

150 - 250mm / 6 - 10"

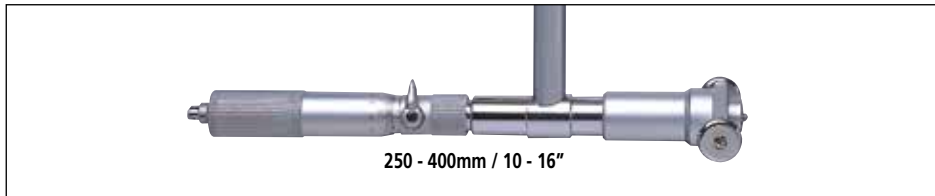

250 - 400mm / 10 - 16"

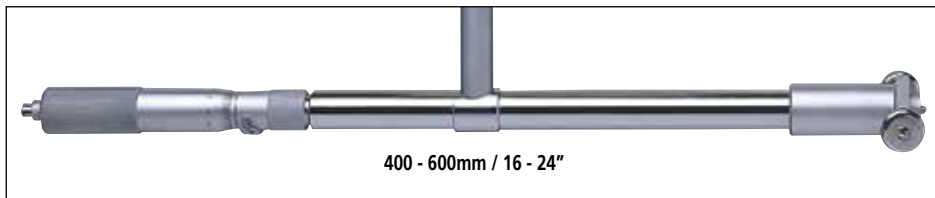

400 - 600mm / 16 - 24"

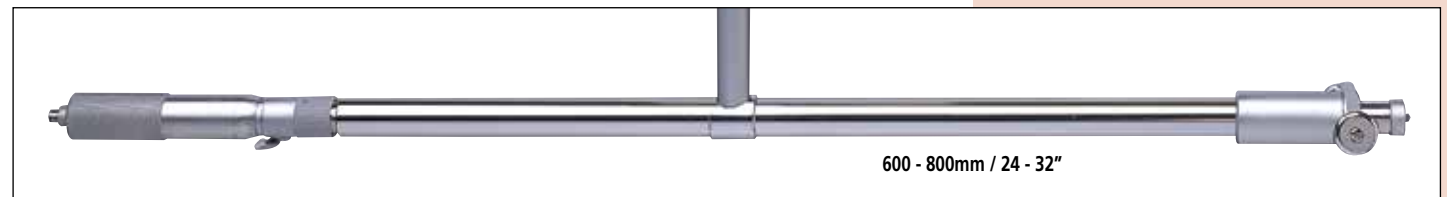

600 - 800mm / 24 - 32"

DIMENSIONS

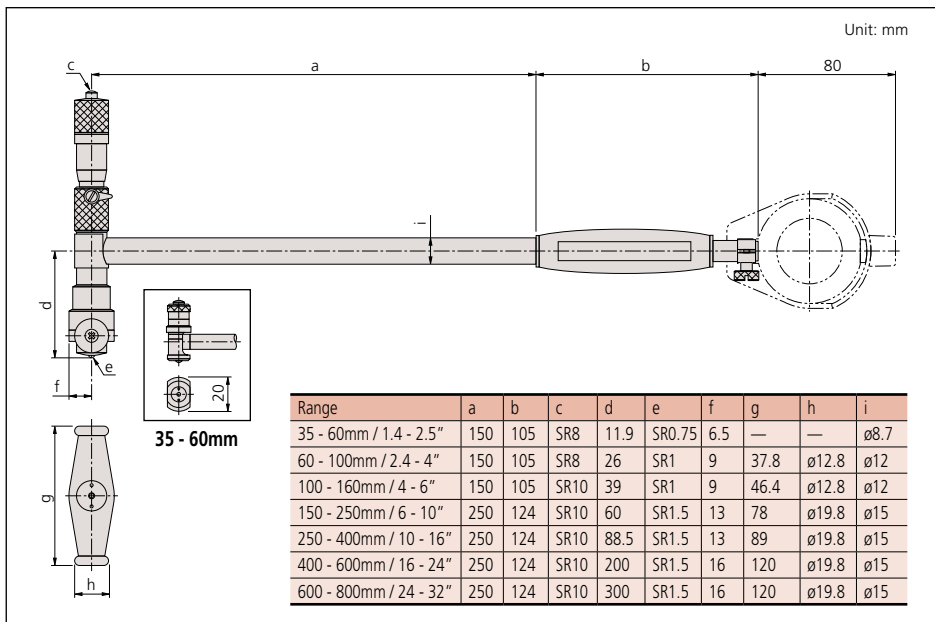



SPC

ABSOLUTE
Absolute System Patented by MITUTOYO

Technical Data

Accuracy: Wide Range: 0.003mm / .00012"
Resolution: .00005" / 0.001mm
Display: LCD
Battery: SR44 (1 pc.) (938882)
Battery life: Approx. 9 months for normal use
Dust/Water protection level: Conforming to IP53

Functions

Origin-set, Zero-Setting, Presetting, Power on/off, inch/mm conversion (inch/mm type only), Data output, go/no-go tolerance judgment
Alarm: Low battery voltage, scale contamination, over-flow error, tolerance limit setting error

Optional Accessories

- 21DZA089: Extension rod 250 mm (10")
- 21DZA081: Extension rod 500 mm (20")
- 516-118-10: Origin setup metric rectangular gage block set
- 516-119-10: Origin setup metric square gage block set
- 516-120-26: GB calibration kit for series 511 bore gage. (9 pcs GB and plain jaw, 160mm holder)
- 905338: SPC cable (40" / 1m)
- 905409: SPC cable (80" / 2m)
- : Setting ring (See page C-29.)



Origin setup gage block set

Example: using four extension rods.

ABSOLUTE Digimatic Bore Gage

SERIES 511

This ABSOLUTE Digimatic bore gage is exclusively designed for ID measurement.



511-521

FEATURES

- The minimum value holding function provides the easy detection of hole diameter.



- Up to three sets of master value and upper/lower tolerance value can be memorized.
- An analog bar indicator is integrated to enhance the intuition in reading.
- Go/no-go judgment is performed by setting the upper and lower tolerances.
- Up to four rods (250mm or 500mm) can be used.

SPECIFICATIONS

Inch/Metric		
Range	Order No.	Probe depth
1.8 - 4" / 45 - 100mm	511-521	6" (152.4mm)
4 - 6.5" / 100 - 160mm	511-522	6" (152.4mm)

DIMENSIONS AND MASS

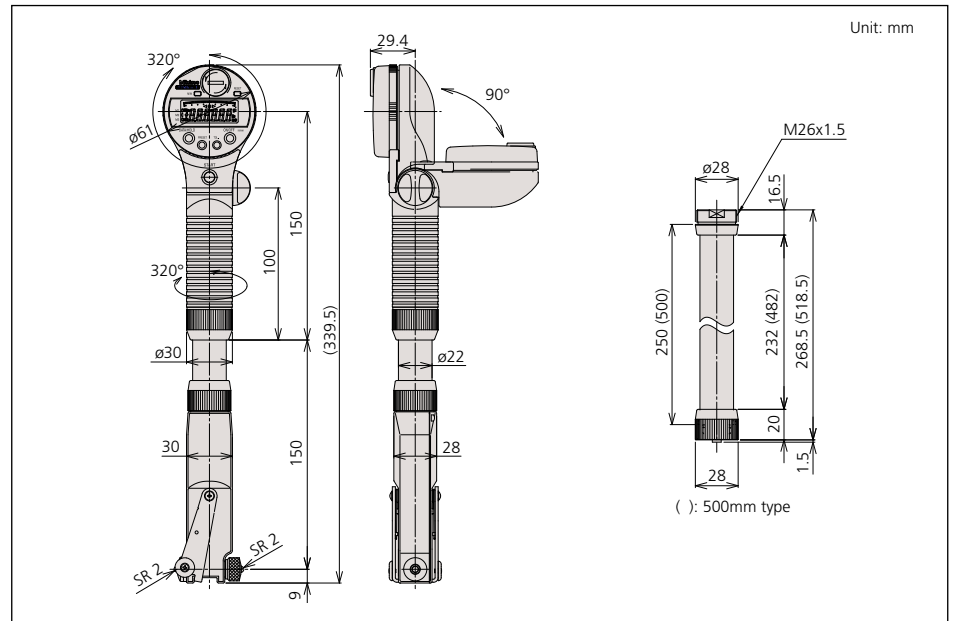

MASS: 500g

Bore Gages

SERIES 526 — for Extra Small Holes

These bore gages measure diameters of small holes. The radial displacement of split-ball contact is converted to axial displacement of measuring rod, which is shown on the dial indicator.

FEATURES

- Optional stand (215-120-10) is available for efficient measurement of multiple small holes.

SPECIFICATIONS

Metric		Gage Stem \varnothing 8mm					
Measuring Range	Order No. Without Dial Gage	Order No. With 2046SB Graduation 0.01mm	Order No. With 2195SB-10 Graduation 0.001mm	Number of Anvils	Number of Needles	Probe depth (D)	Setting Rings
0.95 - 1.55mm	526-170*	526-173	526-172	5	1	11.5mm	5
1.5 - 4mm	526-160*	526-163	526-162	9	2	17.5, 22.5mm	9
3.7 - 7.3mm	526-150*	526-153	526-152	7	1	32mm	7
7 - 10mm	526-101*	526-126	526-124	6	1	56mm	
10 - 18mm	526-102*	526-127	526-125	8	1	62mm	

*Does not come with Dial Gage Protector (21DZA000)

Inch		Gage Stem Dia .375"					
Measuring Range	Order No. Without Dial Gage	Order No. With 2922SB Graduation .0005"	Order No. With 2923SB-10 Graduation .0001"	Number of Anvils	Number of Needles	Probe depth (D)	Setting Rings
.037 - .061"	526-175*	—	526-176	5	1	.45"	5
.06 - .157"	526-165*	—	526-166	9	2	.68", .89"	9
.145 - .29"	526-155*	—	526-156	7	1	1.26"	7
.3 - .4"	526-103*	526-119	526-122	6	1	2.2"	
.4 - .7"	526-104*	526-120	526-123	8	1	2.4"	

*Does not come with Dial Gage Protector (21DZA000)

DIMENSIONS

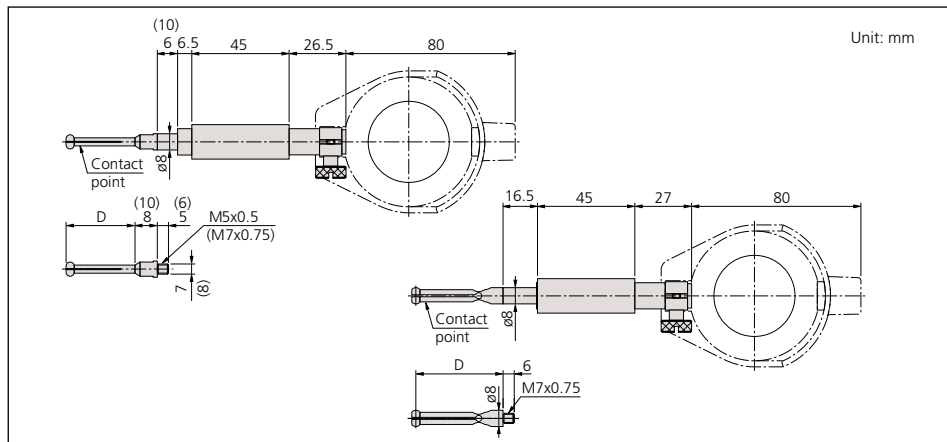

DIAL FACES

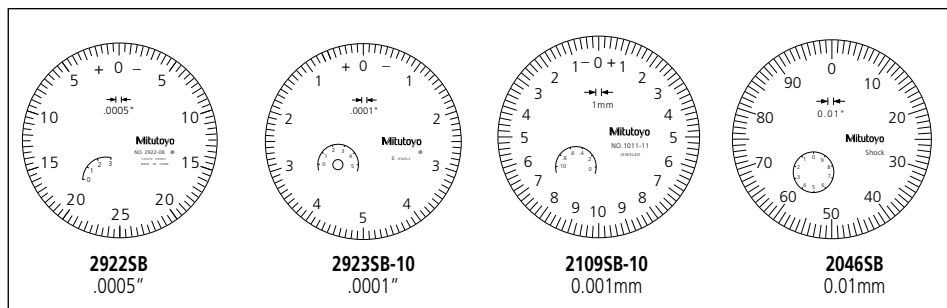

526-172

526-127

Technical Data

Accuracy: $4\mu\text{m} / .00016''$
 Indication stability: $2\mu\text{m} / .00008''$
 Graduation: 0.01mm, 0.001mm, .0005" or .00001"

Contact Point

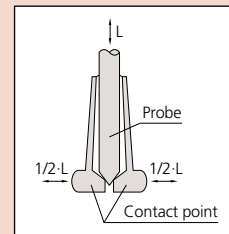

Optional Accessory

215-120-10: Bore gage stand



----- : Setting ring (See page C-29.)