

Mu-checker Probes

SERIES 519 Mu-checker Probes (Lever head)

SPECIFICATIONS

Lever heads

Order No.	519-521	519-522	519-326*	519-327
Measuring range (mm)	±0.5			
Stroke (mm)	±0.6			±0.65
Measuring force (N)	Approx. 0.2	Approx. 0.02	Approx. 0.15	
Linearity (%)	±0.3			±0.5
Stylus support	Pivot bearing	Pivot bearing	Parallel-leaf spring	Pivot bearing

Note: A $\varnothing 2\text{mm}$ ball-ended stylus is supplied as standard with all probes.

* This model is immune to cosine error.

519-521

- Interchangeable styli:
 $\varnothing 1$: 520940 (Standard)
 $\varnothing 2$: 520939 (Standard)
 $\varnothing 3$: 520938 (Standard)

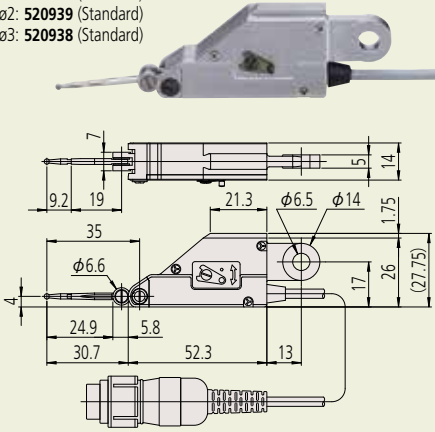

519-522

- Interchangeable styli:
 $\varnothing 1$: 520940 (Standard)
 $\varnothing 2$: 520939 (Standard)
 $\varnothing 3$: 520938 (Standard)

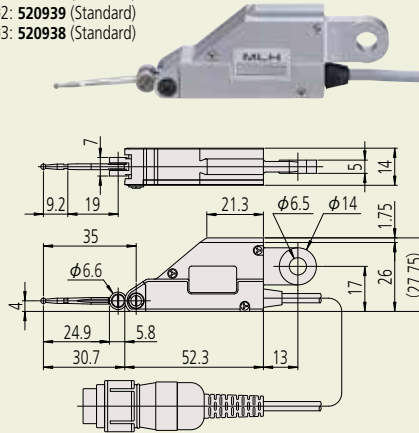

519-326

- Interchangeable styli:
 $\varnothing 1$: 102824 (Option)
 $\varnothing 2$: 102825 (Standard)
 $\varnothing 3$: 102826 (Option)

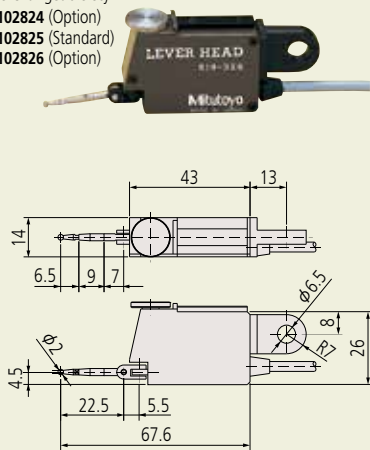

519-327

- Interchangeable styli:
 $\varnothing 1$: 102824 (Option)
 $\varnothing 2$: 102825 (Standard)
 $\varnothing 3$: 102826 (Option)

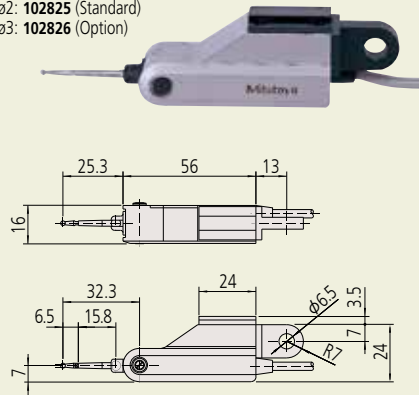

Common specifications

- Connection: Half-bridge
- Cable length: 2m
- Connector type: MAS-5100 (DIN5P) or equivalent

■ Lever probes

Lever probes are available in two types. The most common type uses a pivoted stylus so the contact point moves in a circular arc; this type is subject to cosine effect and, therefore, measurements may require linearity correction if the direction of measurement is much different to the direction of movement of the contact point. The less common type uses a parallel translation leaf-spring mechanism so contact point movement is linear; this type requires no correction.

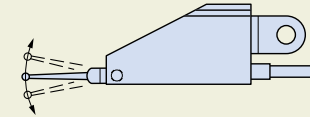

Pivoted stylus type

519-521 (measuring direction can be switched with the up/down lever)

519-522 (measuring direction is not switchable, low force)

519-327 (Clutchless)

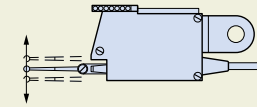

Parallel translation type

519-326 (measuring direction can be switched with the upper dial)



Refer to Bulletin No. (2215) for more details.

Lever-head mounting brackets (optional)

Optional accessories for Mitutoyo test indicators can be used.

Stems

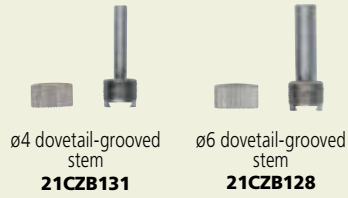

Clamp

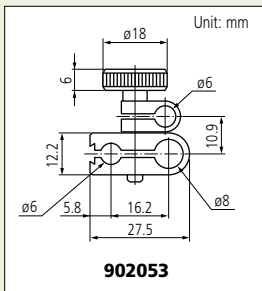

Holder

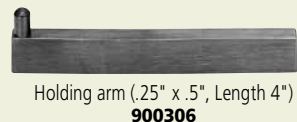
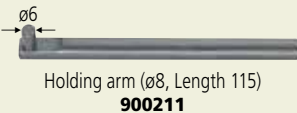
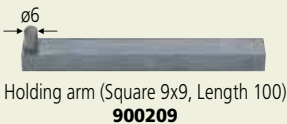

SERIES 519 Mu-checker Probes (Cartridge head)

SPECIFICATIONS

Cartridge heads

Order No.	519-331	519-332	519-346	519-347	519-385	519-341	519-348
Measuring range (mm)	±0.5	±0.5	±0.25	±0.5	±1.5	±2.5	±1.0
Stroke (mm)	±0.65	±0.65	+0.34 -0.26	+0.85 -0.65	+2.35 -1.65	+3.2 -2.8	+1.35 -1.15
Measuring force (N)	Approx. 0.25	Approx. 0.25	Approx. 0.7	Approx. 0.7	Approx. 0.7	Approx. 0.9	Approx. 0.7
Stem Dia. (mm)	ø8	ø3/8"	ø8	ø8	ø8	ø8	ø8
Linearity (%)	±0.5	±0.5	±0.3	±0.3	±0.3	±0.5	±0.3
Plunger support	Plain bearing			Linear ball-bearing			

519-331/(519-332)

- M2.5x5 (4-48 UNF) interchangeable contact points for dial indicators can be used.

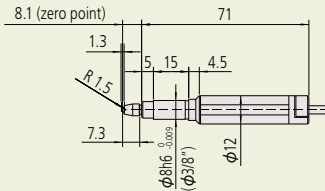

519-346

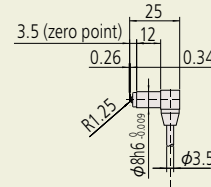

519-347

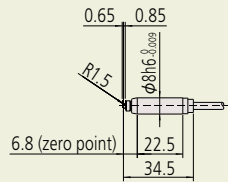

519-385

- M2.5x5 interchangeable contact points for dial indicators can be used.

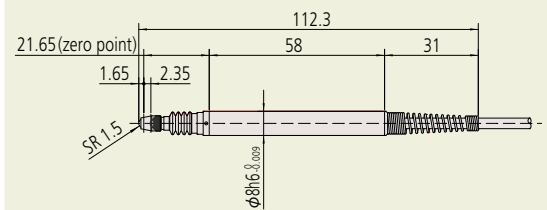

519-341

- M2.5x5 interchangeable contact points for dial indicators can be used.

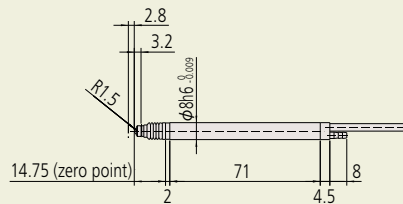

519-348

- M2.5x5 interchangeable contact points for dial indicators can be used.

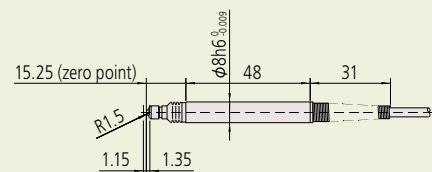

Mu-checker

SERIES 519 Mu-checker (Analog/Digital electronic micrometer)

- Single touch zero-set function is standard.
- Switchable measurement ranges make the Mu-checker suitable for a range of applications.

Analog Mu-checker



Standard type
519-552A



Differential type
519-554A

SPECIFICATIONS

Order No.	519-552A	519-554A
Type	Standard type (one probe required)	Differential type (one/two probes required)
Display range	$\pm 5\mu\text{m}/\pm 15\mu\text{m}/\pm 50\mu\text{m}/\pm 150\mu\text{m}/\pm 500\mu\text{m}/\pm 1500\mu\text{m}$ $\pm .00015"/\pm .0005"/\pm .0015"/\pm .005"/\pm .015"/\pm .05"$	
Resolution	0.1 $\mu\text{m}/0.5\mu\text{m}/1\mu\text{m}/5\mu\text{m}/10\mu\text{m}/50\mu\text{m}$.000005"/.00001"/.00005"/.0001"/.0005"/.001"	
Differential mode	$\pm A$	$\pm A, \pm B, \pm A \pm B$
Display accuracy (linearity)	$\pm 1\%$ / \pm full scale	
Analog output	$\pm 1\text{V}$ \pm full scale	
Analog output accuracy	$\pm 0.1\%$ Within \pm full scale (excluding probe)	
Zero-setting adjustment range	Manual	Instant zero setting: 1/3 of full scale for each range
External dimensions	134(W) x 183(D) x 208(H) mm	
Mass	2.4kg	
Power input	AC adapter 100, 120, 220, 240VAC 50/60Hz	
Probe	Various probes (refer to page G-33 and G-34)	

Digital Mu-checker

- Single touch zero-set function is standard.
- Switchable measurement ranges make the Mu-checker suitable for a range of applications.
- Dual input.



Digital Mu-checker
519-562A

SPECIFICATIONS

Order No.	519-562A
Type	Differential type digital Mu-Checker (2 connecting heads)
Display range	$\pm 2.000\text{mm}/\pm 0.2000\text{mm}/\pm .08"/\pm .008"$
Resolution	0.001mm/0.0001mm/.00005"/.000005"
Differential mode	$\pm A, \pm B, \pm A \pm B$
Measurement mode	ABS/CMP
Analog output	$\pm 1\text{V}$ \pm Full scale
Digital output	Digimatic code out
External dimension	134(W) x 183(D) x 208(H) mm
Mass	Approx. 2.6kg
Power input	AC adapter 100, 120, 220, 240VAC 50/60Hz
Probe	Various probes (refer to page G-33 and G-34)

Optional Accessories

- SPC Cable for connecting digital Mu-checker (**936937**)
Used for connecting to the digimatic mini-processor.
- Output cable A (**934795**)
Used for connecting to external devices, such as data recorders, etc.

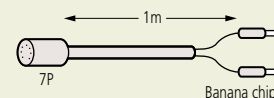

- Analog, limit out (7P) connector (**529035**)
Used for output to external data recorders, sequencers, etc.

- Foot Switch: **937179T**
 - SPC Cable, 1m: **936937**
 - SPC Cable, 2m: **965014**
- Note: for Digital Mu-Checker only

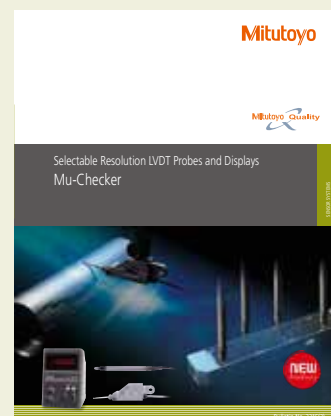

Refer to Bulletin No. (2215) for more details.

SERIES 519 6CH Mu-checker Counter EV-16A

Main features

- External control (Zero-set, Preset etc.)
- Direction switching
- Error messaging
- Tolerance judgment output
- Each data output (RS-232C, BCD, segment)
- Peak measurement (maximum value, minimum value, runout) and arithmetic operation (addition, average, maximum value, minimum value, maximum width) between axes

Optional Accessories

- I/O output connector: **02ADB440**
- D-EV external unit: **02ADD400**
- SPC cable, 0.5m: **02ADD950**
- SPC cable, 1m: **936937**
- SPC cable, 2m: **965014**

- Note 1: To perform calibration a **D-EV (02ADD400)** display unit is required.
At least one **D-EV (02ADD400)** unit is required when using multiple **EV-16A (519-355)**.
- Note 2: As a power supply is not supplied as standard. An appropriate power supply with a current capacity of 1A or more must be provided for each **EV-16A (519-355)**.

- The EV-16A counter unit provides multi-channel electronic micrometer functionality but without a display of the measurement results, which must be purchased separately. (See below.)
- Up to six probes can be connected to one unit. Up to ten counters can be connected to one personal computer using the RS Link function to enable the configuration of a multi-point measurement system comprising a maximum of 60 gages.
- I/O outputs for RS-232C, BCD, tolerance judgment and segment output are available.
- Maximum, minimum and runout measurement between channels (in the same unit) is possible in addition to normal measurement on individual channels.



SYSTEM CONFIGURATION

Mitutoyo probes, EV-16A counters and D-EV display units combined with commercial controllers and personal computers enable construction of a powerful, multi-channel system that can be built to meet the needs of almost any measurement application.

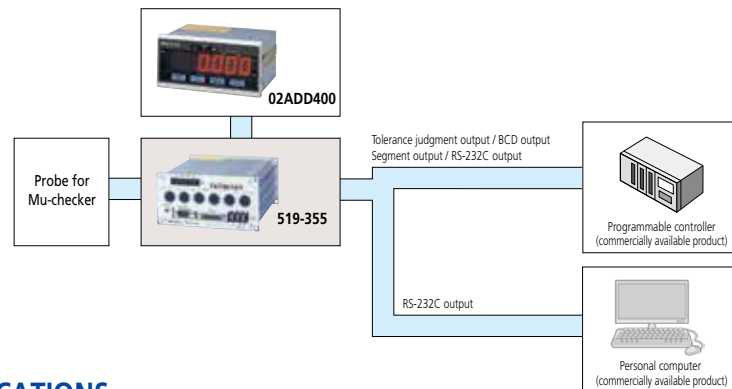

DIMENSIONS

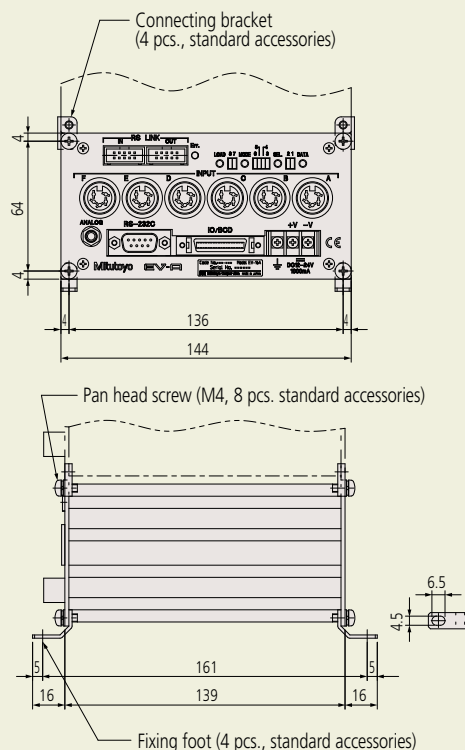

SPECIFICATIONS

Order No.	519-355	
Number of gage inputs	Six	
Display range (mm)	±2.000, ±0.200	
Resolution (mm)	0.001, 0.0001	
Display processing	8 digits for parameters (display setting), 1 for error display	
Error messaging	Power supply voltage error, Gage error, etc.	
External display	Dedicated external display unit D-EV (optional) can be connected	
Number of input switches	4	
Input switch function	Measurement mode switching, Parameter settings	
I/O	Tolerance judgment output	1 to 6 gages (L1, L2, L3), open-collector
	BCD output	Parallel BCD output (positive/negative-true logic), open-collector
	Segment output	A function to enable only output from the terminal corresponding to the counting values, open-collector
	Control output	Normal operation signal (NOM), open-collector
	Control input	Output channel designation (segment, in BCD mode), presetting, peak value clear, range changeover (at segment output), holding counting value, open-collector or no-voltage contact signal (with/without contact point)
Interface	RS-232C	Measurement data output and control input, EIA RS-232C-compatible Use cross cables for home position DTE (terminal definition)
	RS link	Max. connected units: 10 (6 when using EF counter) Connecting cable length: Max. 10m (sum of link cable length) Data transfer time: 1.1 sec./60ch (when transmission rate is 19200 bps)
Rating	Power supply voltage	Terminal (M3 screw), 12-24VDC
	Current consumption	1A
Operating temperature (humidity) range	0 to 40 °C (RH 20 to 80%, no condensation)	
Storage temperature (humidity) range	-10 to 50 °C (RH 20 to 80%, no condensation)	
External dimensions	144(W) × 72(H) × 139(D) mm	
Mass	Approx. 1000 g	
Standard accessories	Fixing foot (4), connecting bracket (4), fixing screw M4 × 8 (8)	
Applicable probes	For probes, refer to 519 series Mu-checker probes	