



# Ranger® 7000

Compact Bench Scales



## ***Simplifying Even the Most Complex Industrial Applications***

For Ranger 7000, there is one resounding theme: it offers the best of every ingenious feature that make OHAUS industrial products the right tools for your toughest weighing jobs. Ranger 7000 boasts the highest resolution, largest display, most application modes and connectivity options, as well as the largest memory library of any industrial bench scale in the OHAUS portfolio.

### ***Standard Features Include:***

- **Advanced Features Take Industrial Weighing to the Next Level** — Ranger 7000 has ten advanced application modes for a variety of complex applications which minimize the need for manual calculations, and can also control peripheral devices and/or a scale platform with option kit.
- **Fast Performance and Legal for Trade Certifications assure Accurate Results** — With a one second stabilization time, up to 75,000d or 350,000d display resolution and legal for trade certifications, Ranger 7000 provides the precision that cannot be matched by any scale in its class.
- **Sturdy Industrial and Modular Design Support Flexible and Heavy-Duty Use** — Ranger 7000 was developed to thrive in rugged and harsh industrial environments. This modular scale was built with IP54 cast metal housing and sealed metal indicator to ensure durability.
- **Cutting-Edge SmarText™ 2.0 Software Powers the Technologically Advanced Ranger 7000** — With SmarText 2.0 software and a 4.3 inch graphic display, the advanced functionality of Ranger 7000 is simple to use with minimal training.

# Ranger® 7000 Compact Bench Scales

## Advanced Features Take Industrial Weighing to the Next Level

With ten advanced application modes, including formulation and density weighing, Ranger 7000 can meet the weighing and measurement needs of practically any industrial application or manufacturing process. Many application modes eliminate the need to do long and complicated manual calculations.

Ranger 7000 contains a 300 item library for storage of weighing, check, counting, and filling data and 30 item library for formulation data, ensuring abundant space for all data storage needs.

With the remote base option, you can connect a floor scale platform or bench scale base with higher capacity in order to achieve precise results for a job of any size. Results from both scales can be displayed at the same time. Ranger 7000 can control many peripheral devices through the optional Discrete I/O interface (provides 2 input ports and 4 output ports), which can be used for accurate weight measurement in filling and checkweighing applications.

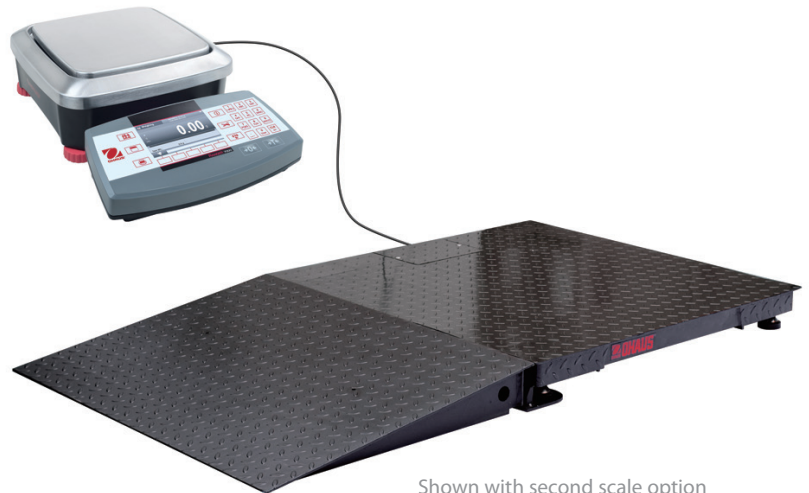

Shown with second scale option

## Fast Performance and Legal for Trade Certifications Assure Accurate Results

Ranger 7000 standard models have an extremely precise display resolution up to 75,000d (7,500d certified). This incredible resolution can only be outdone by the Ranger 7000 high resolution models which offer a maximum 350,000d (35,000d certified) resolution. R71MHD35 drives extreme precision with 0.1g readability for demanding industrial processing and testing applications where capacity and high resolution precision is the standard.

No matter which version you choose, you can be guaranteed that your results will be available in just one second from the time the load is placed on the platform, improving operator efficiency, productivity, and throughput. This ideal combination of features ensures two of the most important aspects of your weighing results: that they are highly accurate, and delivered quickly.

All Ranger 7000 models meet or exceed the Class II / Class III accuracy requirements in accordance with NIST Handbook 44 and Canada's Weights and Measures Regulations.



# Ranger<sup>®</sup> 7000 Compact Bench Scales

## Sturdy Industrial and Modular Design Support Flexible and Heavy-Duty Use

It is a common knowledge that industrial scales are not always delicately handled and Ranger 7000 was built to withstand heavy duty usage. Ranger 7000 has a die-cast sealed metal indicator and housing, ensuring its accurate and long-term operation in even the most demanding industrial environments. The indicator can be separated from the platform and mounted to the wall or bench with the optional mounting kit accessory, allowing you to customize the placement of your scale based on the size and setup of your workstation.

Additionally, a weigh below hook offers the functionality to perform specific gravity tests or weigh items that cannot be easily placed on the weighing platform.



Weight below hook in use



Shown with optional tower mount

## Cutting-Edge SmarText™ 2.0 Software Powers the Technologically Advanced Ranger 7000

The SmarText 2.0 interface will have you easily using the Ranger 7000 for all of its unique and advanced features quickly. SmartText 2.0 makes an advanced scale very simple to use, and will greatly reduce training time for operators. It is also simple to set up and can be configured with just a few button presses.

Ranger 7000 has a bright backlit display and navigation panel that is comprised of a keypad with 5 quick, 8 function, and 12 alphanumeric keys and a 4.3 inch graphic display, which can be operated in multiple languages.



## Standard Connectivity with Flexible Options

The data produced by Ranger 7000 can be easily exported through the standard RS232 or USB device port. Additional connectivity options include a second RS232 or Ethernet, and standard USB host port for bar code scanner or flash drive. Through the RS232/USB/Ethernet and barcode scanner, a complete inventory control system can be set up through a single scale, considerably reducing the investment associated with more complex systems. With full GLP/GMP data output, Ranger 7000 can help meet traceability and compliance requirements.



# Ranger<sup>®</sup> 7000 Compact Bench Scales

## Print Templates

A total of seven print templates are available to ensure you can print out all of the data you need. Simple and standard pre-defined templates are available for quick printing as well as five templates you can customize so you can print the exact information necessary for your application, eliminating confusion and time to sift through excess unnecessary data.

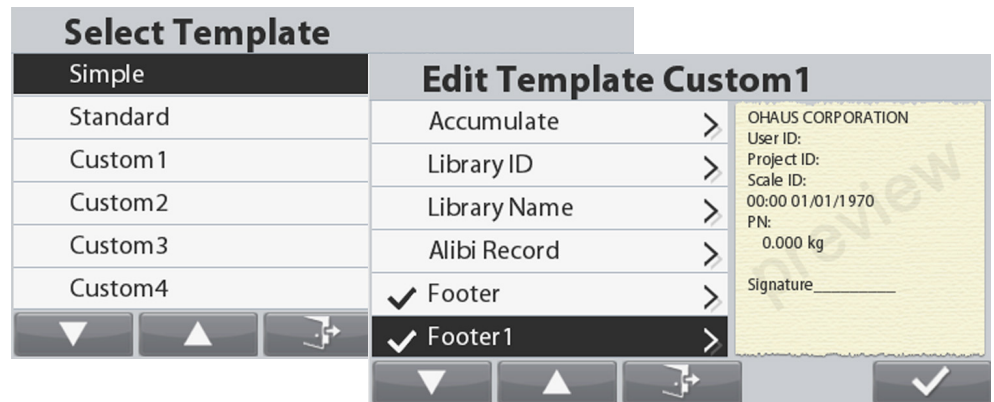

## Other Standard Features and Equipment

Removable stainless steel platform, check weighing lights with selectable operation and audible signal settings, integral weigh below hook, sealed front panel, menu lock switch, level indicator, adjustable leveling feet, six selectable operating languages (English, Spanish, French, German, Italian, etc), selectable environmental and auto-print settings, stability indicator, overload/underload indicators, selectable brightness settings, auto-dim, auto-sleep, auto tare, chain tare.

## Approvals

- **Metrology:** NIST Handbook 44 (NTEP CC 14-033), Measurement Canada Weights and Measures Regulations (AM-5940), (Class II, nmax 35000; Class III, nmax 7500)
- **Product Safety:** CSA C22.2 No. 60950-1, UL 60950-1, IEC 60950-1
- **Electromagnetic Compatibility:** FCC Part 15 Class A, ICES-001 Class A, IEC 61326-1 (emissions Class B, immunity Industrial requirements)

## Accessories

<b>Alibi Memory Kit</b> .....	80500503
<b>2nd RS232 Kit</b> .....	30037448
<b>Painted Column Kit</b> .....	30095408
<b>Discrete I/O Kit</b> .....	30097591
<b>Ethernet Kit</b> .....	30037447
<b>Cable Extension Kit, 9m</b> .....	30101495
<b>Remote Base Kit</b> .....	30097590
<b>Rechargeable Battery</b> .....	30041295
<b>SF40A Impact Printer</b> .....	30064203
<b>In Use Cover</b> .....	30135320

# Ranger<sup>®</sup> 7000 Compact Bench Scales

## Advanced Application Modes



### Weighing

Determine the weight of items in the selected unit of measure.

\*A statistics feature can be used in conjunction with weighing mode in order to compare the relative deviation of a number of samples and other statistical data.



### Dynamic Weighing

Weigh an unstable load. Scale takes an average of weights over a period of time.

\*A Display Hold feature manually or automatically holds the last stable weight on the display. (Activated by setting time interval of Dynamic Weighing to zero.)



### Density Determination

Determine density of solids. With the weigh below hook, it's possible to perform specific gravity tests for objects that cannot be easily placed on the weighing pan.



### Formulation

For compounding and recipe making. Available "compensation mode" which enables recalculation in case component added is outside the tolerance.



### Filling

Fill a container to a target weight. Progress bar displays filling status. Connect with Discrete I/O option kit for auto-filling system.



### Check Weighing/Counting

Compare the weight/count of a sample against target limits. Connect with Discrete I/O option kit for external check lights.



### Differential Weighing

Calculate the difference between sample weights and initial weights.



### Percent Weighing

Measure the weight of a sample displayed as a percentage of a pre-established Reference Weight.



### Parts Counting

Count samples of uniform weight. Advanced auto-optimization software recalculates the average piece weight as the overall weight increases.

## Outline Dimensions

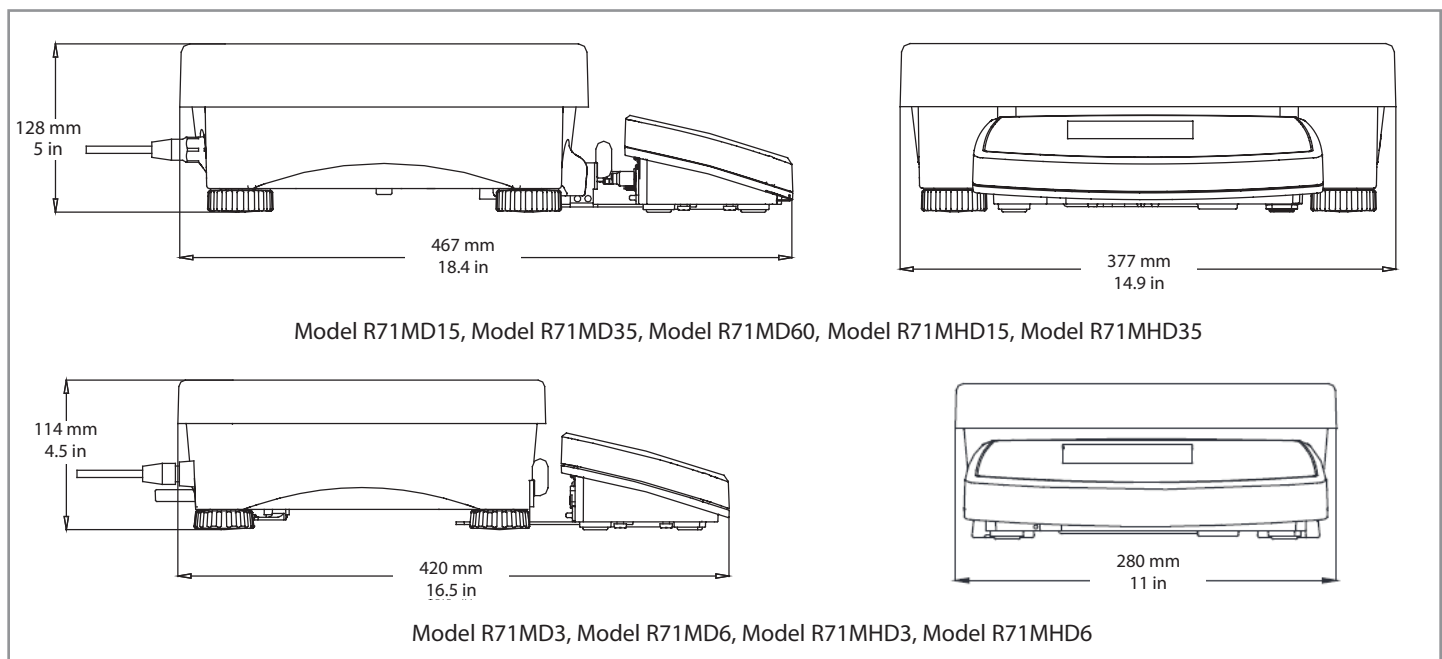

# Ranger® 7000 Compact Bench Scales

## General Specifications

Weighing Units	kg, g, lb, oz, lb:oz
Application Modes	Weighing, Parts Counting, Percent Weighing, Check Weighing, Dynamic Weighing (Display Hold), Filling, Formulation, Differential Weighing, Density Weighing
Display	4.3" TFT Graphic LCD
Keypad	8 function, 5 quick, 12 numeric membrane keys
Construction	Stainless Steel Platform, Die Cast Housing
Protection	IP54
Stabilization Time	1 second
Zeroing Range	2% or 10% of Capacity
Safe Overload Capacity	150% of capacity
Interface	Standard RS232, USB Device, USB Host
	Optional Ethernet, 2 <sup>nd</sup> RS232, Remote Base, 2 In/4 Out digital I/O
Power	100-240 VAC / 50/60 Hz Universal Power Supply, rechargeable lithium battery (Optional)
Display Dimensions (W × D × H)	267 × 118 × 72 mm / 10.5 × 4.6 × 2.8 in

## Technical Specifications

Model	R71MD3	R71MD6	R71MD15	R71MD35	R71MD60
Capacity × Readability	3 kg × 0.00005 kg 3,000 g × 0.05 g 6 lb × 0.0001 lb 96 oz × 0.002 oz	6 kg × 0.0001 kg 6,000 g × 0.1 g 15 lb × 0.0002 lb 240 oz × 0.005 oz	15 kg × 0.0002 kg 15,000g × 0.2 g 30 lb × 0.0005 lb 480 oz × 0.01 oz	35 kg × 0.0005 kg 35,000 g × 0.5 g 70 lb × 0.001 lb 1,120 oz × 0.02 oz	60 kg × 0.001 kg 60,000 g × 1 g 150 lb × 0.002 lb 2,400 oz × 0.05 oz
Maximum Displayed Resolution	1:60,000	1:75,000	1:75,000	1:70,000	1:75,000
Internal Counting Resolution	1: 1,200,000	1: 1,500,000	1: 1,500,000	1: 1,400,000	1: 1,500,000
Certified Capacity × Readability	3 kg × 0.0005 kg 3,000 g × 0.5 g 6 lb × 0.001 lb 96 oz × 0.02 oz	6 kg × 0.001 kg 6,000 g × 1 g 15 lb × 0.002 lb 240 oz × 0.05 oz	15 kg × 0.002 kg 15,000g × 2 g 30 lb × 0.005 lb 480 oz × 0.1 oz	35 kg × 0.005 kg 35,000 g × 5 g 70 lb × 0.01 lb 1,120 oz × 0.2 oz	60 kg × 0.01 kg 60,000 g × 10 g 150 lb × 0.02 lb 2,400 oz × 0.5 oz
Certified/Approved Resolution	1:6,000	1:7,500	1:7,500	1:7,000	1:7,500
Linearity/Repeatability	±2d				
Base Housing Dimensions (W × D × minH)	280 × 280 × 114 mm/11 × 11 × 4.5 in		377 × 311 × 128 mm/14.9 × 12.2 × 5 in		
Platform Dimensions (W × D × H)	280 × 280 × 31 mm/11 × 11 × 1.2 in		377 × 311 × 48mm/14.8 × 12.2 × 1.9 in		
Net Weight	6.8 kg / 15 lb		9.9 kg / 21.8 lb		
Shipping Weight	8.5 kg / 18.7 lb		13.4 kg / 29.5 lb		
Shipping Dimensions	605 × 405 × 244 mm / 23.8 × 15.9 × 9.6 in		665 × 525 × 330 mm / 26.2 × 20.7 × 13 in		
Calibration	Span or Linear				
Battery Life	12 hours continuous use				

Model	R71MHD3	R71MHD6	R71MHD15	R71MHD35
Capacity × Readability	3 kg × 0.00001 kg 3,000 g × 0.01 g 6 lb × 0.00002 lb 96 oz × 0.0005 oz	6 kg × 0.00002 kg 6,000 g × 0.02 g 15 lb × 0.00005 lb 240 oz × 0.001 oz	15 kg × 0.0001 kg 15,000 g × 0.1 g 30 lb × 0.0002 lb 480 oz × 0.005 oz	35 kg × 0.0001 kg 35,000 g × 0.1 g 70 lb × 0.0002 lb 1,120 oz × 0.005 oz
Maximum Displayed Resolution	1:300,000	1:300,000	1:150,000	1:350,000
Internal Counting Resolution	1: 6,000,000	1: 6,000,000	1: 3,000,000	1: 7,000,000
Certified Capacity × Readability	3 kg × 0.0001 kg 3,000 g × 0.1 g 6 lb × 0.0002 lb 96 oz × 0.005 oz	6 kg × 0.0002 kg 6,000 g × 0.2 g 15 lb × 0.0005 lb 240 oz × 0.01 oz	15 kg × 0.001 kg 15,000 g × 1 g 30 lb × 0.002 lb 480 oz × 0.05 oz	35 kg × 0.001 kg 35,000 g × 1 g 70 lb × 0.002 lb 1,120 oz × 0.05 oz
Certified/Approved Resolution	1:30,000	1:30,000	1:15,000	1:35,000
Linearity/Repeatability	±2d			
Base Housing Dimensions (W × D × minH)	280 × 280 × 114 mm 11 × 11 × 4.5 in		377 × 311 × 128 mm 14.9 × 12.2 × 5 in	
Platform Dimensions (W × D × H)	240 × 240 × 15 mm 9.4 × 9.4 × 0.6 in		377 × 311 × 48mm 14.8 × 12.2 × 1.9 in	
Net Weight	7.2 kg / 16 lb		10.9 kg / 24 lb	
Shipping Weight	9.2 kg / 20.3 lb		14.4 kg / 31.7 lb	
Shipping Dimensions	605 × 405 × 244 mm / 23.8 × 15.9 × 9.6 in		665 × 525 × 330 mm / 26.2 × 20.7 × 13 in	
Calibration	InCal™ internal calibration, Span or Linear			
Battery Life	9 hours continuous use			



1 Regan Road, Unit 1  
Brampton, Ontario, Canada  
L7A 1B8

Tel. 905 595 1000  
Sales@MRMmetrology.com  
Service@MRMmetrology.com  
www.MRMmetrology.com