

Technical Data

Main scale adjustment: 15mm or 25mm
Slider fine feed: 4mm, 6mm, 7mm or 20mm

Standard Scriber Provided

Up to 600mm: Carbide-tipped scriber (**07GZA000**) and scriber clamp (**05GZA033**)
0 - 1000mm: Carbide-tipped scriber (**905200**) and scriber clamp (**05GZA033**)
0 - 1500mm: Carbide-tipped scriber (**900390**) and scriber clamp (**905008**)

Dimension of scriber

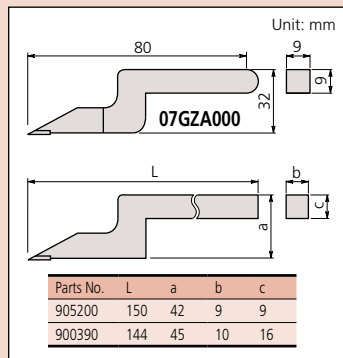

Optional Accessories

07GZA003: Magnifier for 300, 450mm, 600mm models
07GZA015: Magnifier for 1000mm and 1500mm models
953638: Holding bar for test indicator (length: 50mm)
902053: Swivel clamp used with holding bar



Vernier Height Gage

SERIES 514 — Standard Height Gage with Adjustable Main Scale

FEATURES

- Zero reference point can be adjusted.
- Satin chrome-finished scales for glare-free reading.
- Extra-large base for rigidity.
- Optional magnifier for easier reading
- Carbide-tipped scriber is provided.



SPECIFICATIONS

Metric

Range	Order No.	Accuracy	Graduation	Mass (kg)
0 - 300mm	514-102	±0.04mm	0.02mm	3.1
0 - 450mm	514-104	±0.05mm	0.02mm	3.4
0 - 600mm	514-106	±0.05mm	0.02mm	7.4
0 - 1000mm	514-108	±0.07mm	0.02mm	20.0
0 - 1500mm	514-170	±0.18mm	0.02mm	26.0

Inch/Metric

Inch model with inch/metric dual scale

Range	Order No.	Accuracy	Graduation	Mass (kg)
0 - 12" / 0 - 300mm	514-103	±.002"	.001" / 0.02mm	3.1
0 - 18" / 0 - 450mm	514-105	±.002"	.001" / 0.02mm	3.4
0 - 24" / 0 - 600mm	514-107	±.002"	.001" / 0.02mm	7.4
0 - 40" / 0 - 1000mm	514-109	±.003"	.001" / 0.02mm	20.0

DIMENSIONS

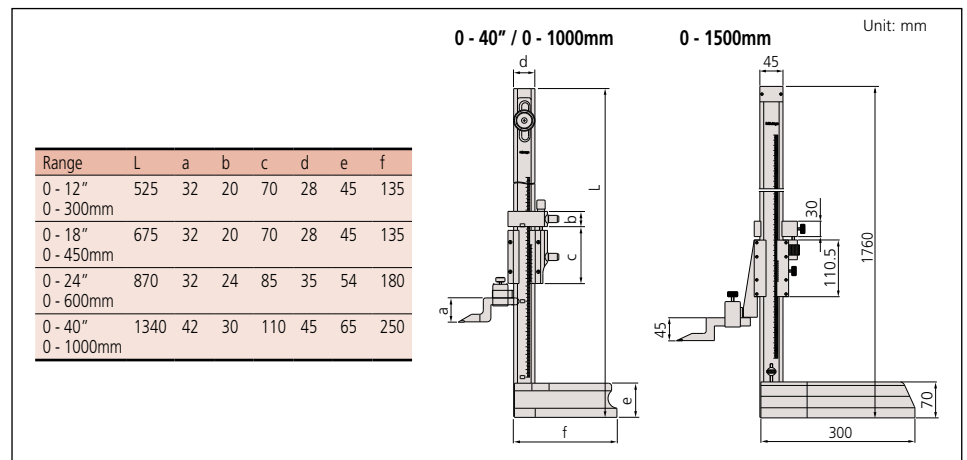

Vernier Height Gage

SERIES 506 — Light-Weight Height Gage

FEATURES

- The Light-Weight Height Gage is designed for scribing from a vertical base or for small parts.
- Satin chrome-finished scales for glare-free reading.
- Beam and slider are made of stainless steel.
- Carbide-tipped scriber is provided.



SPECIFICATIONS

Metric

Range	Order No.	Accuracy	Graduation	Mass (kg)
0 - 200mm	506-207	±0.03mm	0.02mm	1.4

Inch/Metric

Inch model with inch/metric double scale

Range	Order No.	Accuracy	Graduation	Mass (kg)
0 - 8" / 0 - 200mm	506-208	±.001"	.001" / 0.02mm	1.4

DIMENSIONS

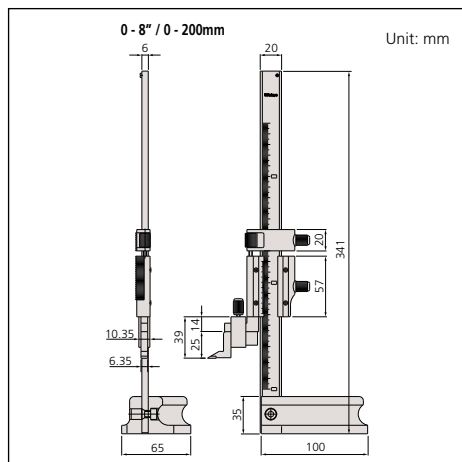

Standard Scriber Provided

Carbide-tipped scriber (900173) and scriber clamp (901338)

Dimension of scriber

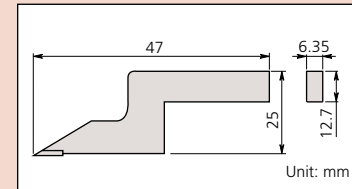

Optional Accessories

- 953639: Holding bar for test indicator (length: 2" / 50mm)
- 900322: Swivel clamp used with holding bar

