



Point Micrometers

SERIES 342, 142, 112

Technical Data

Accuracy: Refer to the list of specifications.
 Resolution*: .00005"/0.001mm or 0.001mm
 Graduation*: .001" or 0.01mm
 Display*: LCD
 Battery*: SR44 (1 pc), **938882**
 Battery life*: Approx. 2.4 years under normal use
 Dust/Water protection level*: IP65
 *Digital models **Analog models

Function of Digital Model

Origin-set, Zero / ABS, Data hold,
 inch/mm conversion (on inch/metric models only)
 Function lock
 Alarm: Low voltage, Counting value composition error

Optional Accessories for Digital Model

05CZA662: SPC cable with data switch (40" / 1m)
05CZA663: SPC cable with data switch (80" / 2m)

FEATURES

- IP65 water/dust protection (Series 342).
- Pointed spindle and anvil for measuring the web thickness of drills, small grooves, keyways, and other hard-to-reach dimensions.
- 15 degree and 30 degree measuring points are available.
- Non-slip grip finish (digital models).
- The measuring points have approximately 0.3mm / .012" radius.
- With ratchet stop for constant force.
- With SPC output (Series 342).
- With digit counter (Series 142).
- With a standard bar except 0 - 1" and 0 - 25mm model.
- Supplied in fitted plastic case.



342-351-30



112-201



Tip angle: 15° (R0.3mm)



Tip angle: 30° (R0.3mm)



SPECIFICATIONS

Metric		Digital model (with carbide tip)				
Range	Resolution	Order No.	Accuracy	Point	Mass (g)	
0 - 25mm	0.001mm	342-251-30	±2µm	15°	330	
		342-261-30	±2µm	30°	330	
25 - 50mm	0.001mm	342-252-30	±2µm	15°	470	
		342-262-30	±2µm	30°	470	
50 - 75mm	0.001mm	342-253-30	±2µm	15°	625	
		342-263-30	±2µm	30°	625	
75 - 100mm	0.001mm	342-254-30	±3µm	15°	565	
		342-264-30	±3µm	30°	565	

Metric		Mechanical Counter Model				
Range	Graduation	Order No.	Accuracy	Point	Mass (g)	
0 - 25mm	0.01mm	142-153*	±3µm	15°	260	
		142-201*	±3µm	30°	260	

Metric		Mechanical Counter Model				
Range	Graduation	Order No.	Accuracy	Point	Mass (g)	
0 - 25mm	0.01mm	112-165	±3µm	15°	205	
		112-153*	±3µm	15°	205	
		112-213	±3µm	30°	205	
		112-201*	±3µm	30°	205	
25 - 50mm	0.01mm	112-166	±3µm	15°	305	
		112-154*	±3µm	15°	305	
		112-214	±3µm	30°	305	
		112-202*	±3µm	30°	305	
50 - 75mm	0.01mm	112-167	±3µm	15°	370	
		112-155*	±3µm	15°	370	
		112-215	±3µm	30°	370	
		112-203*	±3µm	30°	370	
75 - 100mm	0.01mm	112-168	±4µm	15°	500	
		112-156*	±4µm	15°	500	
		112-216	±4µm	30°	500	
		112-204*	±4µm	30°	500	

*The points don't have carbide tips.

Inch/Metric		Digital model (with carbide tip)				
Range	Resolution	Order No.	Accuracy	Point	Mass (g)	
0 - 1" / 0 - 25.4mm	.00005" / 0.001mm	342-351-30	±.0001"	15°	330	
		342-361-30	±.0001"	30°	330	
1" - 2" / 25.4 - 50.8mm	.00005" / 0.001mm	342-352-30	±.0001"	15°	470	
		342-362-30	±.0001"	30°	470	
2" - 3" / 50.8 - 76.2mm	.00005" / 0.001mm	342-353-30	±.0001"	15°	625	
		342-363-30	±.0001"	30°	625	
3" - 4" / 76.2 - 101.6mm	.00005" / 0.001mm	342-354-30	±.00015"	15°	565	
		342-364-30	±.00015"	30°	565	

Inch		Mechanical Counter Model				
Range	Graduation	Order No.	Accuracy	Point	Mass (g)	
0 - 1"	.001"	142-177*	±.00015"	15°	260	
		142-225*	±.00015"	30°	260	

Inch		Mechanical Counter Model				
Range	Graduation	Order No.	Accuracy	Point	Mass (g)	
0 - 1"	.001"	112-189	±.00015"	15°	205	
		112-177*	±.00015"	15°	205	
		112-237	±.00015"	30°	205	
		112-225*	±.00015"	30°	205	
1 - 2"	.001"	112-190	±.00015"	15°	305	
		112-178*	±.00015"	15°	305	
		112-238	±.00015"	30°	305	
		112-226*	±.00015"	30°	305	
2 - 3"	.001"	112-191	±.00015"	15°	370	

*The points don't have carbide tips.

DIMENSIONS

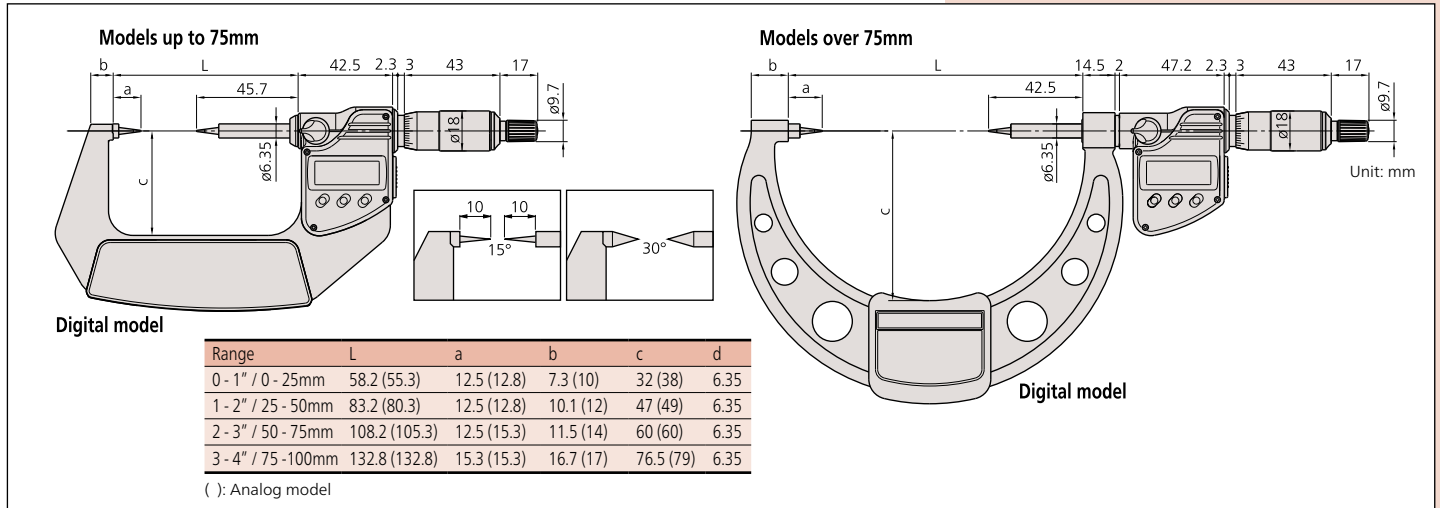

Crimp Height Micrometers

SERIES 342, 142, 112 — Point Spindle and Blade Anvil

FEATURES

- IP54/65 water/dust protection (Series 342).
- Measures the height of crimp contacts.
- With ratchet stop for constant force.
- Non-slip grip finish (digital models)
- With SPC output (Series 342).
- With digit counter (Series 142).
- Supplied in fitted plastic case.



SPECIFICATIONS

Metric Digital model					
Range	Resolution	Order No.	Accuracy	Mass (g)	
0 - 20mm	0.001mm	342-271-30	±3μm	270	

Metric Quickmike type					
Range	Resolution	Order No.	Accuracy	Mass (g)	
0 - 15mm	0.001mm	342-451	±3μm	275	

Metric Mechanical counter model					
Range	Graduation	Order No.	Accuracy	Mass (g)	
0 - 25mm	0.01mm	142-402	±3μm	200	
0 - 25mm	0.001mm	142-403*	±3μm	200	

Inch/Metric Digital model					
Range	Resolution	Order No.	Accuracy	Mass (g)	
0 - 0.8" / 0 - 20mm	.00005" / 0.001mm	342-371-30	±0.0015"	270	

Metric					
Range	Graduation	Order No.	Accuracy	Mass (g)	
0 - 25mm	0.01mm	112-401	±3μm	165	

* 0.001mm reading is obtained with vernier.



Technical Data

Accuracy: Refer to the list of specifications
 Resolution*: .00005" / 0.001mm or 0.001mm
 Graduation**: 0.01mm
 Display*: LCD
 Battery*: SR44 (1 pc), **938882**
 Battery life*: Approx. 2.4 years under normal use (3 years: Quickmike type)
 Dust/Water protection level*: IP65 / IP54
 *Digital models **Analog models

Function of Digital Model

Origin-set, Zero / ABS (342-271 342-371), Data hold, Data output,
 inch/mm conversion (on inch/metric models only)
 Function lock
 Alarm: Low voltage, Counting value composition error

Optional Accessories for Digital Model

- 05CZA662**: SPC cable with data switch (40" / 1m)
- 05CZA663**: SPC cable with data switch (80" / 2m)
- 937387**: SPC cable for Quickmike type (40" / 1m)
- 965013**: SPC cable for Quickmike type (80" / 2m)

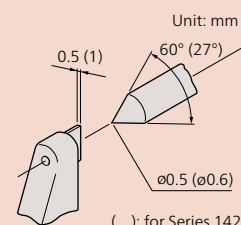

(): for Series 142