

The TSC1000 test stand is ruggedly built for testing up to 1,000 lbf (5 kN) of compression or tension force. A large hand wheel requires little effort, even at high loads, and a precision Acme screw and nut ensures smooth operation over time. The stand includes a loading table with threaded holes for fixture or grip mounting and a solid metal base (TSC1000) contains a storage pocket and holes for bench mounting. Available in vertical and horizontal configurations.

Specifications

Load capacity:	1000 lbf [5 kN]
Maximum travel:	3.50 in [89 mm]
Loading method:	Hand wheel
Travel rate:	0.1 in [2.5 mm] per hand wheel revolution
Weight:	TSC1000: 25 lb [11.4 kg] TSC1000H: 20 lb [9.0 kg]
Warranty:	3 years (see individual statement for further details)

Optional Equipment



Digital travel display TSC001

6 in [150 mm] travel, 0.0005 in [0.01 mm] resolution, 0.001 in [0.03 mm] accuracy, SPC output for data collection.



Horiz. mounting kit TSA002

Converts to a horizontal orientation, for alternative mounting arrangements.

In The Box

The TSC1000 and TSC1000H test stands are shipped as shown at right, and include the following accessories:

- (1) G1028 small hook
- (1) G1038 medium hook
- (1) G1035 large hook
- (1) G1042 extra large hook
- (1) G1009 compression plate, 2" dia.
- (1) G1030 thread adapter, 5/16-18M to #10-32F
- (1) G1044 adapter plate
- (1) Allen wrench set
- (2) #10-32 M/M stud with jam nuts
- (4) Thumb screw for force gauges with 0.12 - 500 lbf capacities
- (4) Thumb screw for force gauges with 1,000 - 2,000 lbf capacities
- (1) Base (TSC1000)
- (2) Mounting leg with hardware (TSC1000H)
- (1) Additional column cap with hardware (TSC1000H)

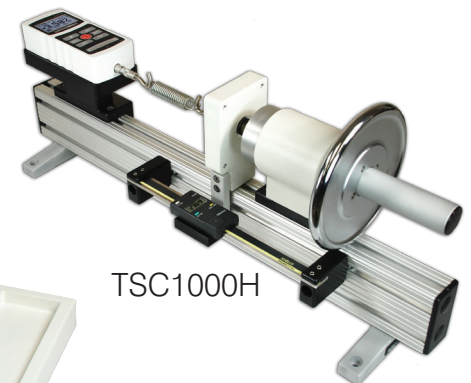

The TSC1000 and TSC1000H are shown in tension spring testing applications, with Series 5 digital force gauge, digital travel display, and hooks



Dimensions

in [mm]

TSC1000

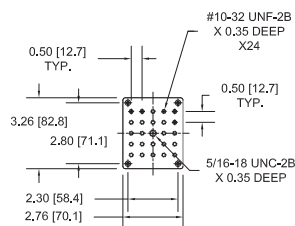
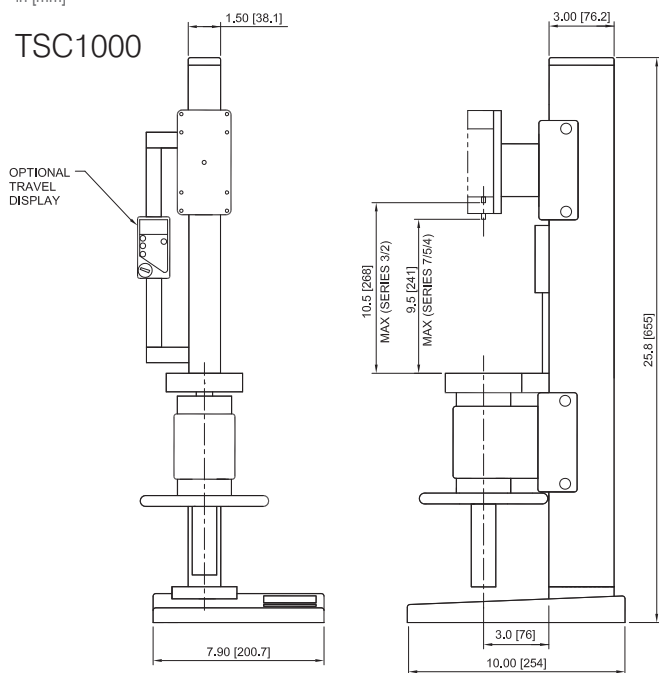

MOUNTING PLATE
TOP VIEW

TSC1000H

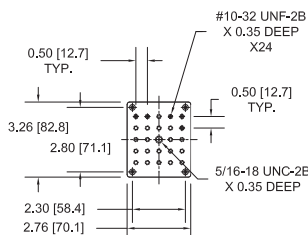
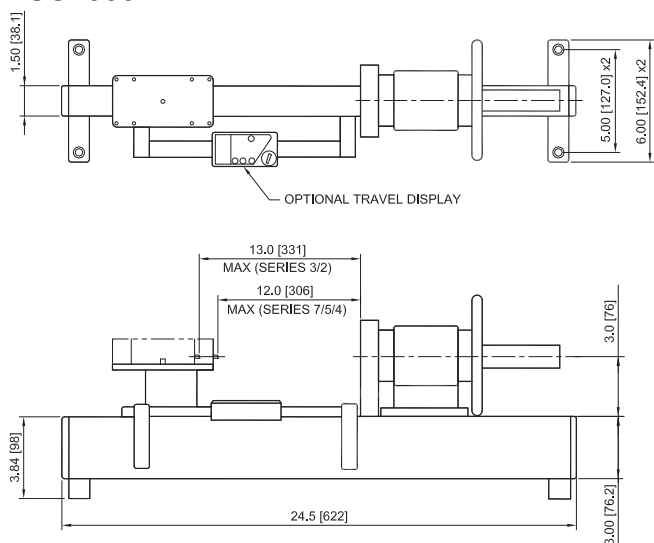

MOUNTING PLATE
TOP VIEW

Ordering Information

Model No.	Description
TSC1000	Test stand, lever-operated, 1000 lbF, vertical
TSC1000H	Test stand, hand wheel-operated, 1000 lbF, horizontal
TSC001	Digital travel display for TSC1000 / TSC1000H
TSA002	Horizontal / wall mounting kit for TSC1000
SP-2734-12	Column extension, 12 in. / 305 mm
SP-2734-24	Column extension, 24 in. / 610 mm
SP-2734-42	Column extension, 42 in. / 1065 mm