



Flagship Balances from OHAUS

When laboratory work and research requires accuracy to the hundred-thousandth, there is simply no room for error. The Explorer series of semi-micro balances has been designed with the technology to ensure that your very specific weighing results are accurate. Sophisticated laboratories requiring accuracy and looking for innovative technology to obtain measurement results can find both in Explorer semi-micro balances.

Standard Features Include:

- The semi-micro Explorer series, which includes models with capacities up to 220 g and resolutions up to 0.01 mg, has been designed to use a High Speed Single Module weighing cell to ensure the accuracy of results. To minimize weighing errors and ensure accurate measurements, AutoCal™ utilizes two internal weights to perform a linear calibration.
- Features such as four-level user management with password protection, and un-editable system log plus a high level of configurability make Explorer balances well suited for regulated applications.
- A detachable terminal with a large color touchscreen, programmable IR sensors, optional built-in Ionizer and automatic doors, and a frameless draftshield make Explorer balances easy and convenient to use.

Explorer[®] Semi-Micro Balances

Intelligent Performance for Applications Requiring Extreme Accuracy

Explorer semi-micro balances offer capacities ranging from 52 g–220g with a readability of 0.01 mg. Superior craftsmanship, a High Speed Single Module weighing cell and a variety of advanced features make Explorer balances well suited for even the most complex weighing tasks.

Weighing Performance

OHAUS' signature AutoCal™ internal calibration system ensures the balance is always ready for use and eliminates the need for manual routine calibration. Explorer's internal calibration mechanism uses multiple weights and adjusts the balance at several points within the weighing range; this results in lower measurement uncertainty than a simple span calibration. Additionally, Explorer balances feature a built-in Repeatability Test, which helps evaluate the balance's performance and aids in determining a suitable minimum weight for applications requiring high accuracy.

Connectivity

Explorer balances include a series of communication interfaces including RS-232, USB, and Ethernet, allowing accessories such as RFID readers, printers and barcode scanners to be connected to the balance. A simple yet complete communication protocol allows Explorer balances to be easily connected to a PC or integrated with larger systems.

Data Management

Explorer balances are equipped with internal databases, which can be used to store, manage, and retrieve application and system data. An internal weighing mode library allows saving and loading of weighing mode configurations. The system event log records changes to the balance's settings, calibrations and adjustments, and user access. System logs can be exported as a non-editable PDF file and saved onto a USB memory stick. A built-in real time clock ensures that the data captured is contemporaneous.

User Management

The user management system allows a system administrator to create up to 110 users and assign them to 1 of 4 pre-existing groups with varying access rights to the balance and enforce password protection ensuring data integrity in a multi-user environment.



User Profiles			
#	User Name	Group	Password
>> 1	Admin	Administrator	
2	Jeremy	Supervisor	*****
3	Jonny	Operator	*****
4	Adam	Log Viewer	*****

New Edit Delete Return to Application

Ingenious Construction Designed to Enhance Usability

The sleek Explorer semi-micro balance has been designed and constructed to provide a modern weighing experience as well as to bolster accuracy.

Operator Experience

Among the features that enhance the operator experience are:

- Color touchscreen display
- Four programmable touchless sensors allow the operator to perform common functions and commands with a swipe of the hand
- Modular design in which the base and display can be separated to allow the balance to fit ideally on the lab bench.



Auto-Doors

The automatic door on certain models allows the user to open the draftshield door with a wave of their left hand when their right hand is occupied with the sample. This feature allows the sample placement process to occur in one swift motion without having to repetitively pick up and put down samples due to a lack of free hands. The automatic doors are more than just a user-friendly feature, they minimize vibrations caused by manual operation which can affect weighing results.



Ionizer

The built-in ionizer, included in Explorer automatic door models, generates bipolar ions continuously from positive and negative discharge electrodes and directs the ionized air onto the charged body to eliminate static electricity. These charges can build up in the weighing chamber and alter weighing results by as much as several milligrams.



Outline Dimensions

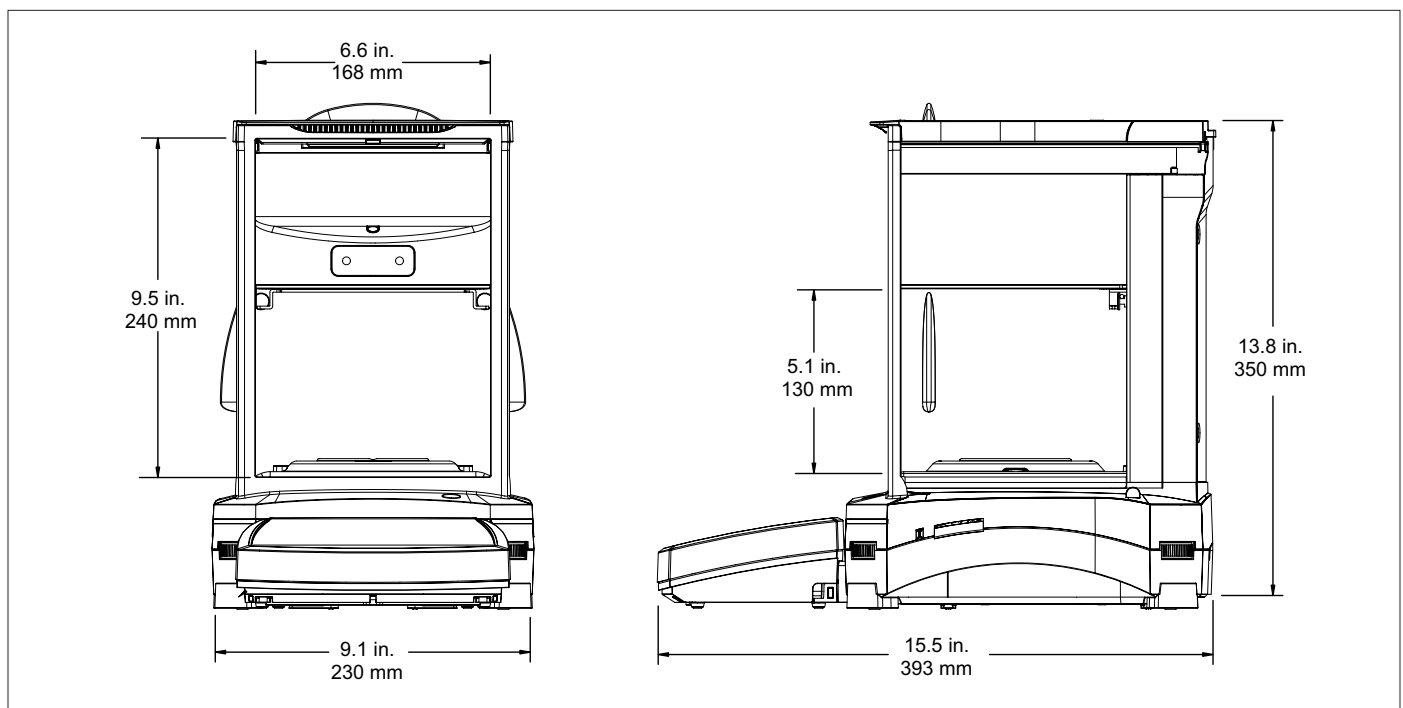

Explorer[®] Semi-Micro Balances

MODEL	EX125D	EX125	EX225D	EX225D/AD	EX225/AD
Capacity	52 g / 120 g	120 g	120 g / 220 g	120 g / 220 g	220 g
Readability (d)	0.01 mg / 0.1 mg	0.01 mg	0.01 mg / 0.1 mg	0.01 mg / 0.1 mg	0.01 mg
Repeatability (20 g) (std. dev.)	0.015 mg				
Repeatability (100 g) std. dev.)	0.1 mg	0.02 mg	0.02 mg / 0.1 mg	0.03 mg	
Linearity	±0.1 mg				
Span Calibration Points	50 g 100g	50 g 100g	100 g 150g 200g	100 g 150g 200g	100 g 150g 200g
Calibration	Standard AutoCal™, AutoCal on Δ1.5° temperature change, 3 hours				
Automatic Door	n/a			Standard*	
Weighing Units	g, mg, kg, ct, gn, oz, ozt, lb, dwt, N, mom, tical, msg, tola, baht, Hong Kong Tael, Singapore Tael, Taiwan Tael, Custom Units 1, Custom Unit 2, Custom Unit 3				
Applications	Weighing, Parts Counting, Percent Weighing, Checkweighing, Dynamic Weighing, Filling, Totalization, Formulation, Differential Weighing, Peak Hold, Density Determination, Pipette Adjustment, Statistical Quality Control				
Stabilization Time	0.1 mg: ≤3 second, 0.01 mg: ≤8 second				
Sensitivity Temp. Drift	0.50 ppm / °C				
Min-Weight (typical)	20.0 mg, fine range (USP, u=0.10%, k=2)				
Min-Weight (optimal)	9.0 mg, fine range (USP, u=0.10%, k=2) SRP≤0.41d**				
Display	5.7 in / 14.5 cm (diagonal) Full-Color touch screen				
Interface	Standard connectivity: 1 USB host, 1 USB device, 1 RS232 Optional connectivity: 2 nd RS232, Ethernet				
Working Environment	10°C – 30°C / 50°F – 86°F, 85% RH, non-condensing				
Storage Conditions	-14°F (10°C) to 140°F (60°C) at 10% to 90% relative humidity, non-condensing				
Power Supply	AC Adapter Input: 100 – 240 VAC 0.6 A 50/60 Hz, AC Adapter Output: 12 VDC 1.5 A				
Pan Size (diameter)	3.1 in / 80 mm				
Dimensions (W × H × D)	9 × 15.5 × 13.8 in / 230 × 393 × 350 mm				
Shipping Dimensions (W × H × D)	24.9 × 25.2 × 18.4 in / 632 × 640 × 467 mm				
Net Weight	15.4 lb / 7 kg			16.5 lb / 7.5 kg	
Shipping Weight	26.5 lb / 12 kg			27.8 lb / 12.6 kg	

** Two motorized doors operated by 4 sensors or onscreen button

*The value for SRP is the standard deviation for n replicate weighing's (n ≥ 10)

Approvals

- **Product Safety:** CAN/CSA C22.2 61010-1, UL 61010-1, IEC 61010-1
- **Electromagnetic Compatibility:** FCC Part 15 (Class A), Industry Canada ICES-001 (Class A), IEC 61326-1, (Class B emissions, Industrial immunity)

Accessories

Ethernet Interface83021082
Terminal Extension Cable83021083
Interface Cable USB83021085
Density Determination Kit80253384
Security Device Kit80850043
Dot Matrix Printer	SF-40A
Cable kit to connect Dot Matrix Printer80252571
Paper for Dot Matrix Printer80251932
Ink Ribbon for Dot Matrix Printer80251933
RS232 Cable, PC 9 Pin80500525
USB Extension Cable30215156
ION-100A Ionizer30130302
Dust Cover30093334

