



Defender[®] 5000

Standard Bench Scales



Counting function is not legal for trade

Multifunctional Bench Scale for Standard Industrial Applications

The OHAUS next generation Defender 5000 Series multifunctional bench scale is ideal for a multitude of applications, including production, packaging, inventory and shipping. Built durably and equipped with advanced features such as maximum configurability print output, GMP/GLP data output, library/user management, and multiple connectivity options - the Defender 5000 is designed to simplify demanding industrial and commercial applications.

Standard Features:

- **Indicator Guides The User with On-Screen Prompts**
See results clearly on the large backlit display. The alpha-numeric keypad and function keys allow for a simplified user experience. On-screen prompts and soft keys will guide you through the operation.
- **Durably Constructed To Withstand Harsh Industrial Environments**
Durably constructed with a stainless steel platform, silver-painted column, and aluminum load cell. Supports up to 6,250e NTEP and Measurement Canada certified resolution for legal-for-trade applications.
- **Multiple Application Modes and High Storage Capacity for Greater Flexibility**
Features common industrial modes and supports a 50,000 item library and 1,000 user profiles which can be downloaded/uploaded for easy set-up with the included Micro SD Card. Also equipped with GLP/GMP output capability with time/date for result traceability. Alibi memory available.
- **Multiple Connectivity Options for Convenient Data Transfer and Storage**
Results can be stored in the Micro SD card. Data output via built-in RS232 or optional interfaces including 2nd RS232/RS485/USB device, Ethernet, Bluetooth/WiFi, Analog Output and Discrete I/O with relays.

Ingeniously Practical

Defender[®] 5000 Standard Bench Scales

Simplified Use

Results can be read easily on the Defender 5000's large transfective dot matrix display, even in bright sunlight. The SmartText 3.0 interface will guide you through all of the Defender 5000's unique and advanced features. With five soft keys, SmartText 3.0 makes an advanced scale very simple to use, and reduces training time for operators.



Durable Construction

The Defender 5000 can be used for both general and legal-for-trade applications. For standard industrial applications, the Defender 5000 bench scales offer durable performance at a practical price.



Simple Operation

Featuring most common applications including Parts Counting with APW optimization, Checkweighing or Checkcounting, Percent Weighing, and Dynamic Weighing or Display Hold, the Defender 5000 meets the weighing and measurement needs of practically every industrial application or manufacturing process. Many application modes eliminate the need for long and complicated manual calculations. GMP/GLP with time/date allows for traceability of results.



Equipped with the included Micro SD card, the Defender 5000 can support storage of up to 50,000 items and 1,000 user profiles. Weighing results can also be stored in Alibi or regular format, addressing all your data storage needs.

Multiple Connectivity Options

Weighing results can be easily exported through the standard RS232 port. Additional connectivity options include a second RS232, RS485 or USB device; Ethernet; and WiFi/Bluetooth interfaces.



Using the Analog Option (either 4-20mA or 0-10V) or the two In/four Out Discrete I/O, the new Defender 5000 indicator can also be used for systems including PLCs.

Indicator Specifications

	TD52P	TD52XW
Construction	ABS plastic	304 stainless steel with sand blasting surface treatment
Protection	N/A	IP68 / NEMA 4X
Weighing Units	lb, oz, lb:oz, kg, g, metric tonnes, short ton, custom unit	
Application Modes	Weighing, Percent Weighing, Piece Counting with Optimized APW, Checkweighing/Checkcounting, Dynamic Weighing/Display Hold	
Display	Dot matrix LCD with white LED backlight, 256 x 80 pixels	
Keyboard	6 function, 5 quick, 12 alpha numeric membrane switches	
Auto-zero Tracking	Off, 0.5 d, 1 d or 3 d	
Zeroing Range	2% or 100% of capacity	
Interface	Standard RS232, Optional Ethernet, WiFi/Bluetooth, RS232/RS485/USB, Analog Output, 2 In/4 Out Discrete I/O	
Power	100-240 VAC / 50/60 Hz Universal Power Supply, Rechargeable Lithium battery (Optional)	
Battery Life	20 hours continuous use	
Calibration	Zero, Span or 3 point-Linear	

Defender® 5000 Standard Bench Scales

Column Mount Bench Scale Specifications

Model	D52P12RQR1	D52P25RQR1	D52P50RQR1	D52P12RTR1	D52P25RTR1	D52P50RTR1	D52P50RQL2	D52P125RQL2
	D52XW12RQR1	D52XW25RQR1	D52XW50RQR1	D52XW12RTR1	D52XW25RTR1	D52XW50RTR1	D52XW50RQL2	D52XW125RQL2
Capacity × Default Readability	25 lb × 0.001 lb 12.5 kg × 0.5 g	50 lb × 0.002 lb 25 kg × 1 g	100 lb × 0.005 lb 50 kg × 2 g	25 lb × 0.001 lb 12.5 kg × 0.5 g	50 lb × 0.002 lb 25 kg × 1 g	100 lb × 0.005 lb 50 kg × 2 g	100 lb × 0.005 lb 50 kg × 2 g	250 lb × 0.01 lb 125 kg × 5 g
Max. Displayed Resolution	1: 25,000							
Capacity × Certified Readability	25 lb × 0.005 lb 12.5 kg × 2 g	50 lb × 0.01 lb 25 kg × 5 g	100 lb × 0.02 lb 50 kg × 10 g	25 lb × 0.005 lb 12.5 kg × 2 g	50 lb × 0.01 lb 25 kg × 5 g	100 lb × 0.02 lb 50 kg × 10 g	100 lb × 0.02 lb 50 kg × 10 g	250 lb × 0.05 lb 125 kg × 20 g
Min APW (g)	0.025	0.05	0.1	0.025	0.05	0.1		0.25
Internal Counting Resolution	1:500,000							
Linearity/Repeatability	±2d							
Indicator	D52P models: TD52P ABS Indicator / D52XW models: TD52XW Stainless Steel Indicator							
Column	13.8 in. / 350 mm powder-coated steel						26.8 in. / 680 mm powder-coated steel	
Base Construction	Stainless steel removable weighing platform, powder-coated steel base construction, aluminum loadcell silicon sealed against moisture							
Safe Overload Capacity	150% of maximum capacity							
Stabilization Time	Within 1 second							
Operating Temp. Range	14 °F to 104 °F / -10 °C to 40 °C							
D52P Scale Dimensions (BxAxCxDxExF)	12 × 12 × 3.7 × 2.4 × 22.6 × 17.4 in 305 × 305 × 95 × 60 × 574 × 442 mm			12 × 14 × 3.9 × 2.4 × 22.6 × 19.3 in 305 × 355 × 99 × 60 × 574 × 491 mm			18 × 18 × 4.3 × 2.8 × 35.6 × 24.7 in 457 × 457 × 110 × 70 × 903 × 627 mm	
D52XW Scale Dimensions (BxAxCxDxExF)	12 × 12 × 3.7 × 2.4 × 23.8 × 17.4 in 305 × 305 × 95 × 60 × 604 × 442 mm			12 × 14 × 3.9 × 2.4 × 23.8 × 19.3 in 305 × 355 × 99 × 60 × 604 × 491 mm			18 × 18 × 4.3 × 2.8 × 36.8 × 24.7 in 457 × 457 × 110 × 70 × 934 × 627 mm	
Shipping Dimensions (L × W × H)	18.9 × 17.5 × 14.3 in 480 × 445 × 363 mm						39.1 × 26.8 × 9.25 in. 994 × 680 × 235 mm	
Approx. Net Weight	D52P: 22 lb / 10 kg D52XW: 24.3 lb / 11 kg			D52P: 24.3 lb / 11 kg D52XW: 26.5 lb / 12 kg			D52P: 37.5 lb / 17 kg D52XW: 39.7 lb / 18 kg	
Approx. Shipping Weight	D52P: 24.3 lb / 11 kg D52XW: 26.5 lb / 12 kg			D52P: 26.5 lb / 12 kg D52XW: 28.7 lb / 13 kg			D52P: 41.9 lb / 19 kg D52XW: 44.1 lb / 20 kg	

Model	D52P50RTX2	D52P125RTX2	D52P250RTX2	D52P50RQV3	D52P125RQV3	D52P250RQV3	D52P500RQV3	D52P125RTV3	D52P250RTV3	D52P500RTV3
	D52XW50RTX2	D52XW125RTX2	D52XW250RTX2	D52XW50RQV3	D52XW125RQV3	D52XW250RQV3	D52XW500RQV3	D52XW125RTV3	D52XW250RTV3	D52XW500RTV3
Capacity × Default Readability	100 lb × 0.005 lb 50 kg × 2 g	250 lb × 0.01 lb 125 kg × 5 g	500 lb × 0.02 lb 250 kg × 10 g	100 lb × 0.005 lb 50 kg × 2 g	250 lb × 0.01 lb 125 kg × 5 g	500 lb × 0.02 lb 250 kg × 10 g	1000 lb × 0.05 lb 500 kg × 20 g	250 lb × 0.01 lb 125 kg × 5 g	500 lb × 0.02 lb 250 kg × 10 g	1000 lb × 0.05 lb 500 kg × 20 g
Max. Displayed Resolution	1: 25,000									
Capacity × Certified Readability	100 lb × 0.02 lb 50 kg × 10 g	250 lb × 0.05 lb 125 kg × 20 g	500 lb × 0.1 lb 250 kg × 50 g	100 lb × 0.02 lb 50 kg × 10 g	250 lb × 0.05 lb 125 kg × 20 g	500 lb × 0.1 lb 250 kg × 50 g	1000 lb × 0.2 lb 500 kg × 100 g	250 lb × 0.05 lb 125 kg × 20 g	500 lb × 0.1 lb 250 kg × 50 g	1000 lb × 0.2 lb 500 kg × 100 g
Min. APW (g)	0.1	0.25	0.5	0.1	0.25	0.5	1	0.25	0.5	1
Internal Counting Resolution	1:500,000									
Linearity/Repeatability	±2d									
Indicator	D52P models: TD52P ABS Indicator / D52XW models: TD52XW Stainless Steel Indicator									
Column	26.8 in. / 680 mm powder-coated steel					38.6 in. / 980 mm powder-coated steel				
Base Construction	Stainless steel removable weighing platform, powder-coated steel base construction, aluminum loadcell silicon sealed against moisture									
Safe Overload Capacity	150% of maximum capacity									
Stabilization Time	Within 1 second									
Operating Temp. Range	14 °F to 104 °F / -10 °C to 40 °C									
D52P Scale Dimensions (BxAxCxDxExF)	18 × 24 × 5.1 × 3.5 × 35.6 × 30.5 in 457 × 610 × 130 × 90 × 903 × 775 mm				24 × 24 × 5.1 × 3.5 × 47.4 × 30.4 in 610 × 610 × 130 × 90 × 1203 × 773 mm			23.6 × 31.5 × 5.2 × 3.5 × 47.4 × 37.9 in 600 × 800 × 132 × 90 × 1203 × 963 mm		
D52XW Scale Dimensions (BxAxCxDxExF)	18 × 24 × 5.1 × 3.5 × 36.8 × 30.5 in 457 × 610 × 130 × 90 × 934 × 775 mm				24 × 24 × 5.1 × 3.5 × 48.6 × 30.4 in 610 × 610 × 130 × 90 × 1234 × 773 mm			23.6 × 31.5 × 5.2 × 3.5 × 48.6 × 37.9 in 600 × 800 × 132 × 90 × 1234 × 963 mm		
Shipping Dimensions (L × W × H)	39.1 × 26.8 × 9.25 in 994 × 680 × 235 mm				45.9 × 30.7 × 9.25 in 1165 × 780 × 235 mm					
Approx. Net Weight	D52P: 59.5 lb / 27 kg / D52XW: 61.7 lb / 28 kg				D52P: 86 lb / 39 kg / D52XW: 88.2 lb / 40 kg			D52P: 103.6 lb / 47 kg / D52XW: 105.8 lb / 48 kg		
Approx. Shipping Weight	D52P: 66.1 lb / 30 kg / D52XW: 68.3 lb / 31 kg				D52P: 92.6 lb / 42 kg / D52XW: 94.8 lb / 43 kg			D52P: 112.4 lb / 51 kg / D52XW: 114.6 lb / 52 kg		

Defender[®] 5000 Standard Bench Scales

Application Modes



Weighing: Determine the weight of items in the selected unit of measure.



Percent Weighing: Measure the weight of a sample displayed as a percentage of a pre-established reference weight.



Parts Counting: Count samples of uniform weight. Advanced auto-optimization software recalculates the average piece of weight as the overall weight increases.



Dynamic Weighing and Display Hold: Weigh an unstable load. Scale takes an average of weights over a period of time. The Display Hold feature manually or automatically holds the last stable weight on the display.



Checkweighing/Counting: Compare the weight/count of a sample against target limits. Connect with Discrete I/O and Light Tower Kit for external check lights.

Other Standard Features and Equipment

User-configurable resolution up to 25,000d for general applications and up to 6,250e for legal-for-trade applications (depending on model and unit of measure), 150% overload capacity protection, checkweighing symbols with selectable operation and audible signal settings, menu lock switch, multiple selectable operating languages, selectable environmental and auto-print settings, stability indicator, overload/underload indicators, selectable adjust contrast settings, auto-dim display, auto-off, auto tare, non-slip adjustable rubber feet, a Wheel Kit option is also available for scales up to 300 kg.

Compliance

- **Metrology:** Measurement Canada (Indicator: NoA AM-6093, Platforms: NoA AM-6107); NTEP (Indicator: CC 18-065, Platforms: CC 18-077) Class III
- **Product Safety:** CAN/CSA C22.2 61010-1; UL61010-1; IEC/EN 61010-1
- **Electromagnetic Compatibility:** FCC Part 15 Class B; Canada ICES-003 Class B; IEC/EN 61326-1 Class B, basic environments
- **Compliance Marks:** CE; CSA

Accessories

Battery Kit, Li-ion, TD52	30424405
USB Host for Dongle, TD52	30424406
Light Tower, 3 Colors, 243mm, IP65 (Requires 30097591)	30424021
In-use Cover Kit, TD52P	30424022
In-use Cover Kit, TD52XW	30424023
In-use Cover set (10), TD52P	30469948
In-use Cover set (10), TD52XW	30469949
Printer Holder Kit, D52	30424025
Wall Mount Kit, SST, TD52XW	30424026
Wall Mount Kit, CS, TD52P	30424027
LC Extension Cable, 9 meters, D52 ¹	30424409

M16 Gland with Ferrite, to TD52	30379716
Micro SD Card, 8G	30303533
Analog Output Kit, TD52 ²	30424403
Second RS232/RS485/USB Kit, TD52 ³	30424404
I/O with Relay (2 In/4 Out) ³	30097591
WiFi/BT Dongle, OHAUS ² (Requires 30424406)	30412537
Ethernet Kit, D52 ²	30429666
Wheel Kit, Defender Series (for bases up to 300 kg) ¹ ..	30372146
Impact Printer SF40A	30064203
Thermal Printer STP-103	80251992

¹ Cannot be used for legal-for-trade applications ² Only one of them can be used at the same time ³ Only one of them can be used at the same time

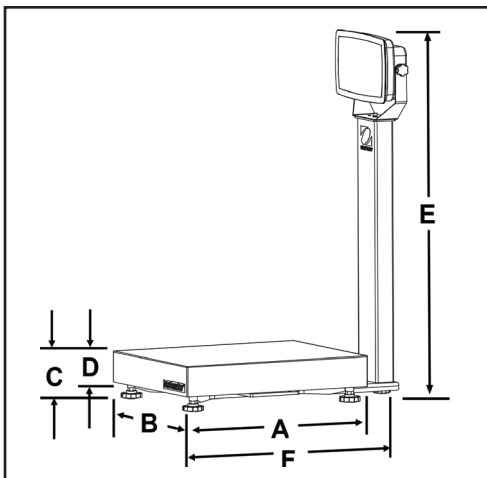

1 Regan Road, Unit 1
Brampton, Ontario, Canada
L7A 1B8

Tel. 905 595 1000
Sales@MRMmetrology.com
Service@MRMmetrology.com
www.MRMmetrology.com